

POSIWIRE[®]

Cable Extension Position Sensors

WS19KT
Position Sensor

Datasheet



Copyright

© ASM Automation Sensorik Messtechnik GmbH
Am Bleichbach 18-24
85452 Moosinning
Germany

The information presented in this data sheet does not form part of any quotation or contract, is believed to be accurate and reliable and may be changed without notice. No liability will be accepted by ASM for any consequence of its use. Publication thereof does not convey nor imply any license under patent or industrial or intellectual property rights. Applications that are described herein for any of these products are for illustrative purpose only.

ASM makes no representation or warranty that such applications will be suitable for the specified use without further testing or modification.

Absolute encoder output	4
Specifications	4
Order code	6
Incremental encoder output	7
Specifications	7
Order code	8
Dimensions	9
Measurement range 2000 ... 3000 mm, absolute encoder output, incremental encoder output	9
Measurement range 5000 mm, absolute encoder output, incremental encoder output	10
Measurement range 8000 mm, absolute encoder output, incremental encoder output	11
Measurement range 15000 mm, absolute encoder output, incremental encoder output	12
Output specifications	13
Incremental outputs	13
Signal conditioner LD5VC	13
Signal conditioner PP24VC	15
Absolute encoder outputs	17
Signal conditioner HSSI	17
Interface HPROF	18
Interface HINT	19
Interface HDEV	20
Interface HCAN / HCANOP	21
Accessories	22
Plug-in connector CONIN, 12 pin (straight coupling)	22

Absolute encoder output

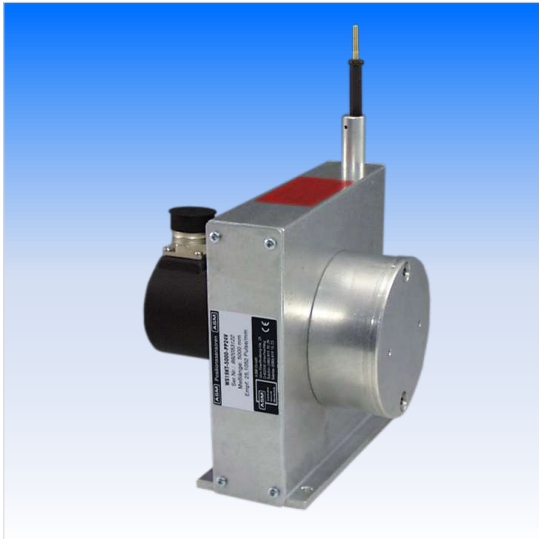

Sensor features

- Measurement range up to 15000 mm
- Protection class IP64
- Absolute encoder output



Specifications

Output	HSSI HPROF HINT HDEV HCAN HCANOP	= Absolute encoder with synchronous serial output (SSI) = Absolute encoder with Profibus interface = Absolute encoder with Interbus interface = Absolute encoder with DeviceNet interface = Absolute encoder with CAN-interface = Absolute encoder with CANopen interface
Resolution for 12 bit per revolution (4096 steps/ revolution)	WS19KT-2000 WS19KT-3000 WS19KT-5000 WS19KT-8000 WS19KT-15000	ResolutionDist/Rev. 0.04 mm 163.84 mm 0.063 mm 260.09 mm 0.10 mm 409.60 mm 0.162 mm 667.90 mm 0.146 mm 600.00 mm
Linearity	±0.05% f.s. (standard) ±0.01% f.s. (optional)	
Sensing device	Absolute encoder	
Housing material	Aluminium measuring cable: stainless steel	
Protection class	IP64	
Connection	Depending on the type of encoder: connector or Bus cover	
Temperature range	-20 ... +85 °C	
Weight	see table "Cable forces"	
EMC	DIN EN 61326-1:2013	

Cable forces typical at = 20 °C	Measurement range [mm]	Weight approx. [kg]	Maximum pull-out force [N]	Minimum pull-in force [N]
	2000	1.3	11.0	6.0
	3000	1.6	8.1	4.9
	5000	3.0	12.0	9.0
	8000	5.6	10.5	6.8
	15000	6.1	16.5	9.1

Order code

WS19KT - 1 - 2 - 3 - 4

1 Measurement range (in mm)

2000 / 3000 / 5000 / 8000 / 15000

2 Output

- HSSI** = Absolute encoder with synchronous serial output (SSI)
- HPROF** = Absolute encoder with Profibus interface
- HINT** = Absolute encoder with Interbus interface
- HDEV** = Absolute encoder with DeviceNet interface
- HCAN** = Absolute encoder with CAN-interface
- HCANOP** = Absolute encoder with CANopen interface

3 Linearity (optional)

L01 = ±0.01% f.s.

4 Cable fixing

- M4** = M4 cable fixing
- SB0** = cable clip

Order example

WS19KT - 3000 - HSSI - M4

Accessories:

Mating connector CONN-CONIN-12F-G (see page 22)

Incremental encoder output

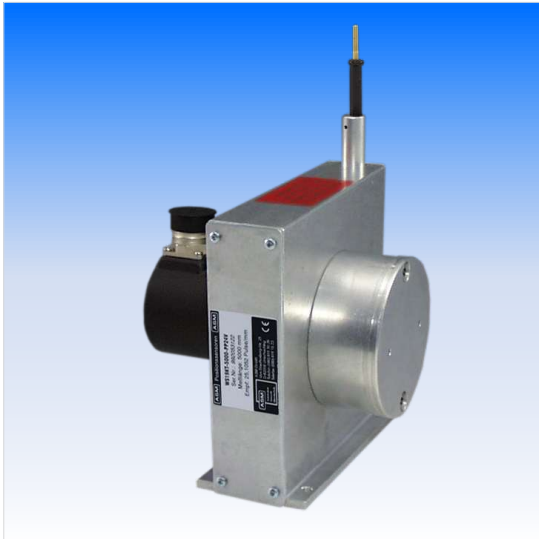

Sensor features

- Measurement range up to 15000 mm
- Protection class IP64
- Incremental encoder output

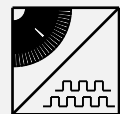

Specifications

Output	LD5VC = Incremental encoder TTL compatible PP24VC = Incremental encoder HTL compatible
Resolution	WS19KT-2000 25 pulses / mm WS19KT-3000 15.75 pulses / mm WS19KT-5000 10 pulses / mm WS19KT-8000 6.13 pulses / mm WS19KT15000 6.83 pulses /mm
Linearity	±0.05% f.s.
Sensing device	Incremental encoder
Housing material	Aluminium measuring cable: stainless steel
Protection class	IP64
Connection	Connector 12 pin
Temperature range	-20 ... +85 °C
Weight	see table "Cable forces"
EMC	DIN EN 61326-1:2013

Cable forces typical at = 20 °C	Measurement range [mm]	Weight approx. [kg]	Maximum pull-out force [N]	Minimum pull-in force [N]
	2000	1.3	11.0	6.0
	3000	1.6	8.1	4.9
	5000	3.0	12.0	9.0
	8000	5.6	10.5	6.8
	15000	6.1	16.5	9.1

Order code

WS19KT - 1 - 2 - 3 - 4

1 Measurement range (in mm)

2000 / 3000 / 5000 / 8000 / 15000

2 Output

LD5VC = Incremental encoder TTL compatible
PP24VC = Incremental encoder HTL compatible

3 Linearity (optional)

L01 = ±0.01% f.s.

4 Cable fixing

M4 = M4 cable fixing
SB0 = cable clip

Order example

WS19KT - 5000 - LD5VC - M4

Accessories:

Mating connector CONN-CONIN-12F-G (see page 22)

Dimensions

Measurement range 2000 ... 3000 mm, absolute encoder output, incremental encoder output

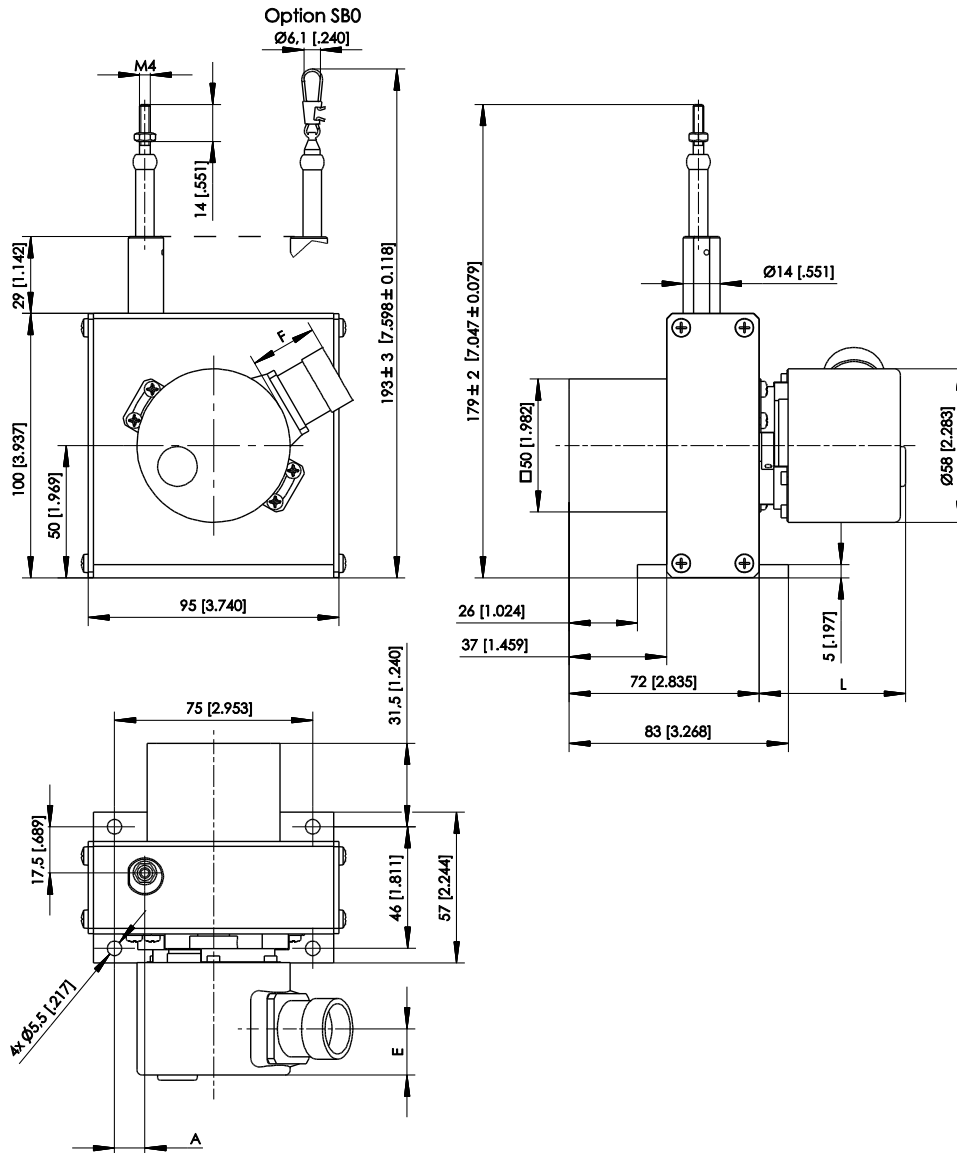

Dimensions in mm	Measurement range	A
	2000	11.5
	3000	0

Dimensions in mm [inch]

Dimensions E, F and L depending on the encoder.

Dimensions informative only. For guaranteed dimensions consult factory.

Measurement range 5000 mm, absolute encoder output, incremental encoder output

Option SB0

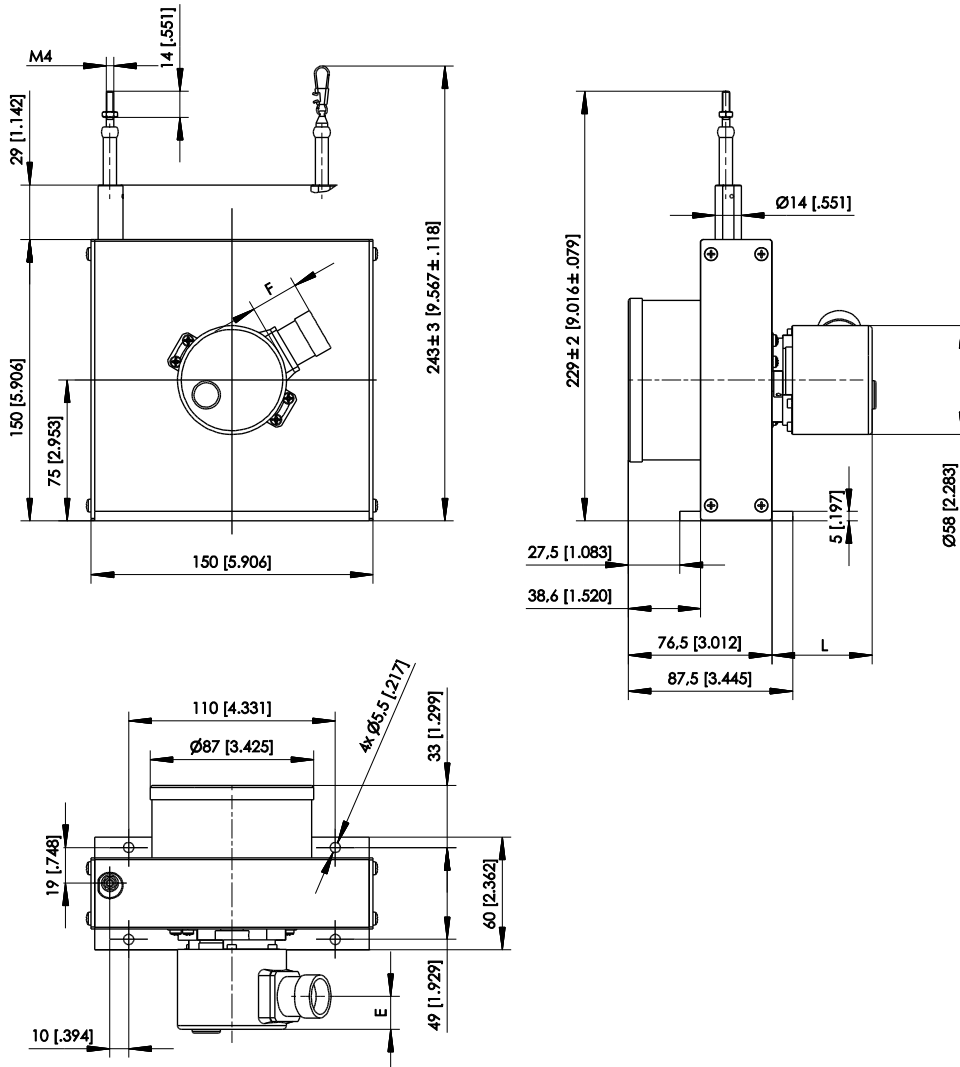

Dimensions in mm [inch]
 Dimensions E, F und L depending on the encoder.
 Dimensions informative only.
 For guaranteed dimensions consult factory.

Measurement range 8000 mm, absolute encoder output, incremental encoder output

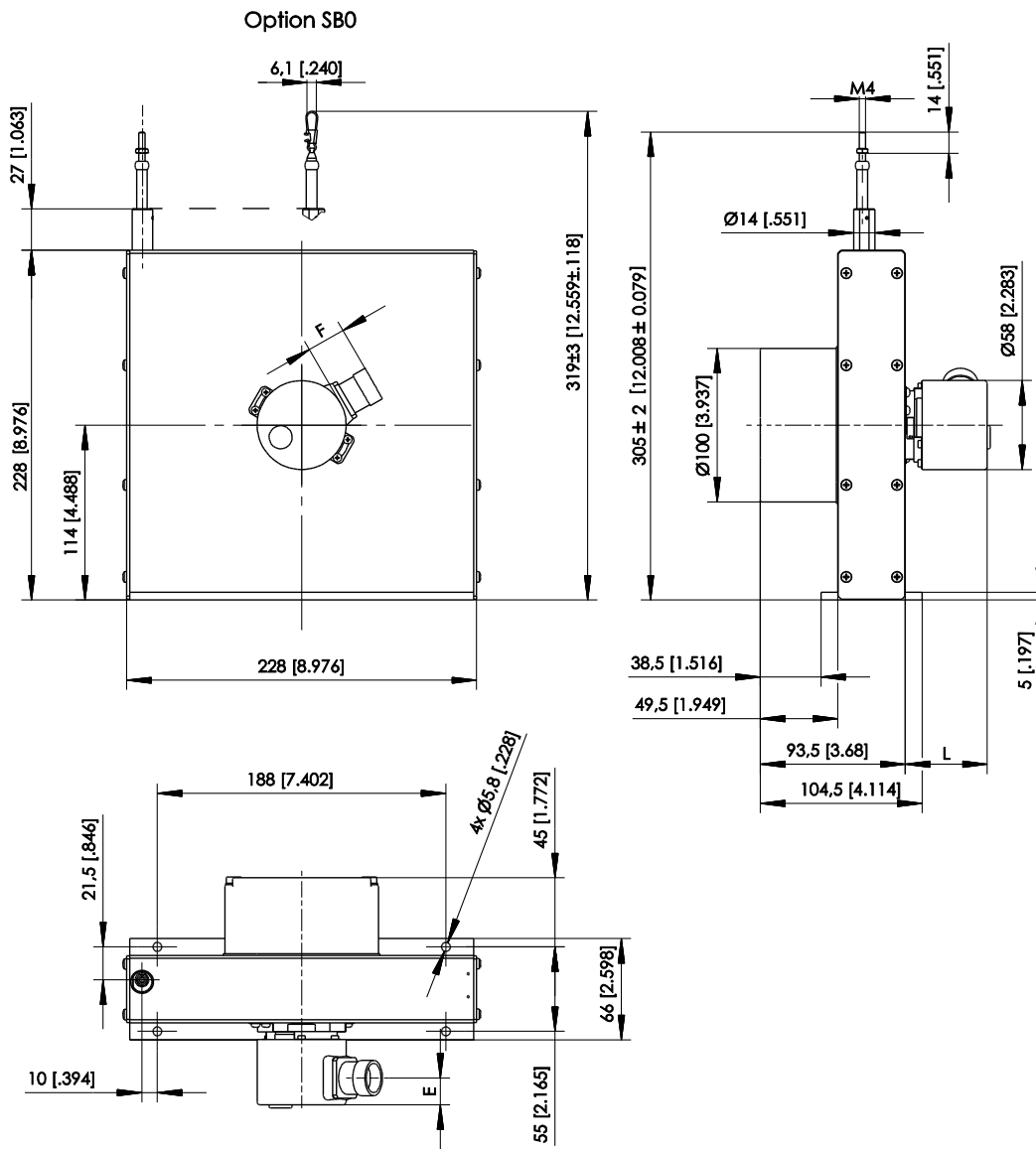

Dimensions in mm [inch]
 Dimensions E, F and L depending on the encoder.
 Dimensions informative only.
 For guaranteed dimensions consult factory.

Measurement range 15000 mm, absolute encoder output, incremental encoder output

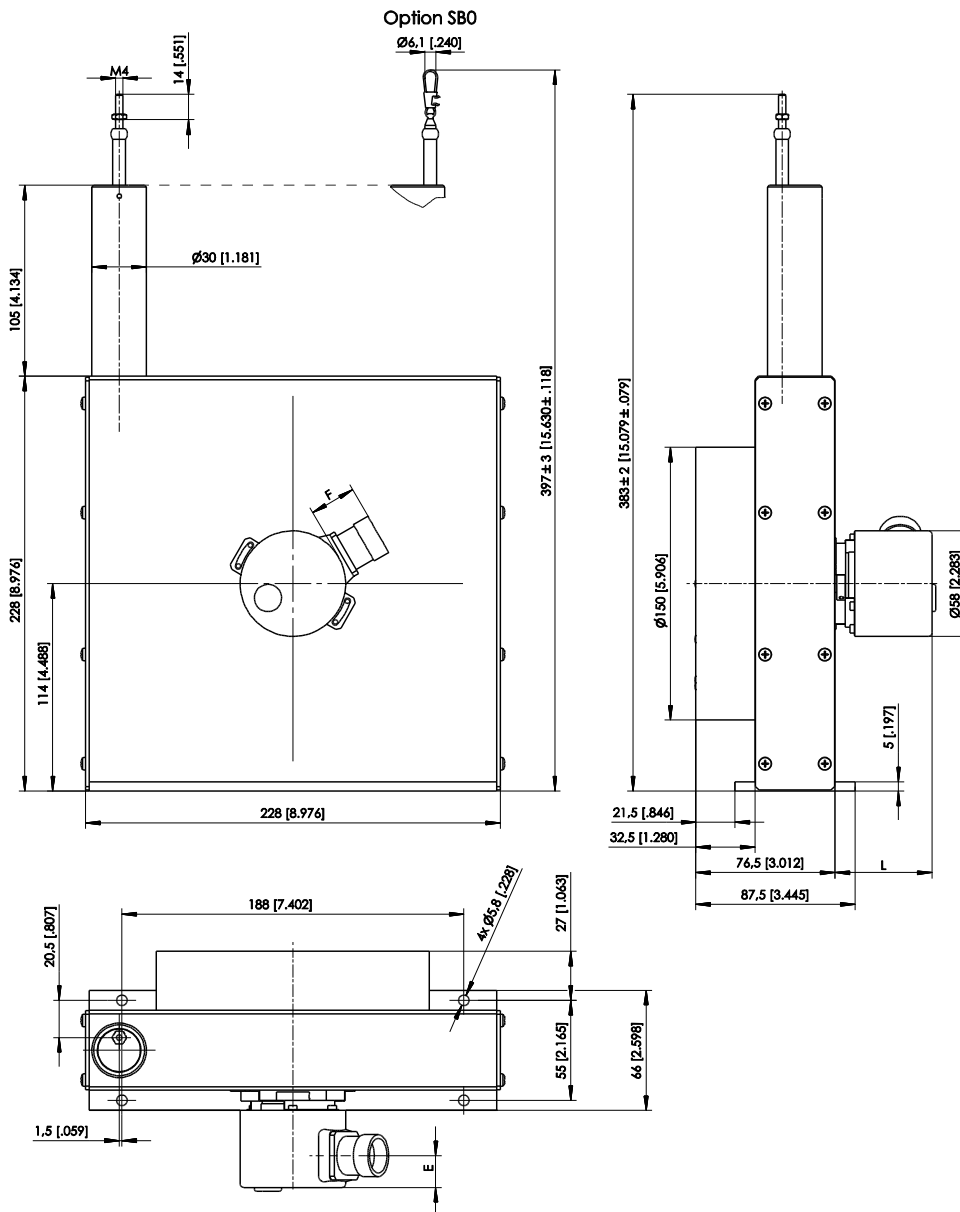

Dimensions in mm [inch]
 Dimensions E, F and L depending on the encoder.
 Dimensions informative only.
 For guaranteed dimensions consult factory.

Output specifications

Incremental outputs

Signal conditioner LD5VC

Incremental 	Excitation voltage	5 V DC ±10 %
	Excitation current	150 mA max. w/o load
	Interface	Line driver RS422
	Output frequency	300 kHz max.
	Output current	20 mA per channel
	Signal level	
	U _d High bei I _d = 20 mA	≥ 2.5 V
	U _d Low bei I _d = 20 mA	≥ 0.5 V
	Transition time positive edge	< 100 ns
	Transition time negative edge	< 100 ns
	Stability (temperature)	±20 x 10 ⁻⁶ / °C f.s. (sensor-mechanism)
	Operation temperature	-20 ... +85 °C
	Protection	Short circuit, overvoltage
	EMC	DIN EN 61326-1:2013

Signal wiring

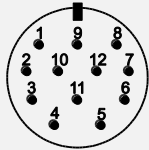
Signal	Connector pin no.	View to sensor connector
Excitation +	12	 <p>CONN-CONIN-12F</p>
Excitation GND	10	
Signal A	5	
Signal \bar{A}	6	
Signal B (A + 90°)	8	
Signal \bar{B}	1	
Signal Z (reference pulse)	3	
Signal \bar{Z}	4	
Fault detection signal	7	
Schirm	housing	

Recommended processing circuit

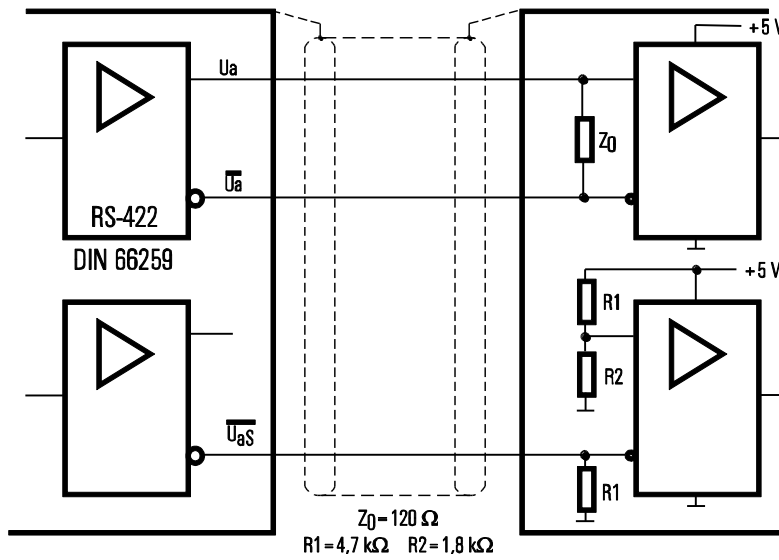

Output signals

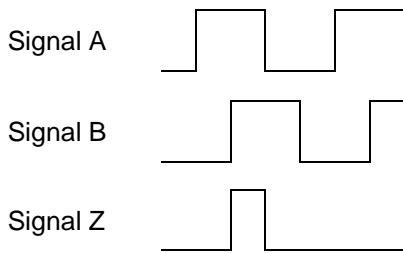

Signal conditioner PP24VC

Incremental 	Excitation voltage	10 ... 30 V DC
	Excitation current	150 mA max. w/o load
	Interface	Push-pull line driver (24 V-HTL)
	Output frequency	300 kHz max.
	Output current	100 mA per channel
	Signal level	
	Ud High at Id = 20 mA, Ub = 24 V	≥ 21 V
	Ud Low at Id = 20 mA, Ub = 24 V	≥ 2.8 V
	Transition time positive edge	< 200 ns
	Transition time negative edge	< 200 ns
	Stability (temperature)	±20 x 10 ⁻⁶ / °C f.s. (sensor mechanism)
	Operating temperature	Refer to output specification
	Protection	Reverse polarity, short circuit, overvoltage
	EMC	DIN EN 61326-1:2013

Signal wiring

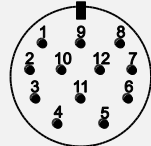
Signal	Connector pin no.	View to sensor connector
Excitation +	12	
Excitation GND	10	
Signal A	5	
Signal \bar{A}	6	
Signal B (A + 90°)	8	
Signal \bar{B}	1	
Signal Z (reference pulse)	3	
Signal \bar{Z}	4	
Fault detection signal	7	
Shield	housing	

CONN-CONIN-12F

Recommended circuit

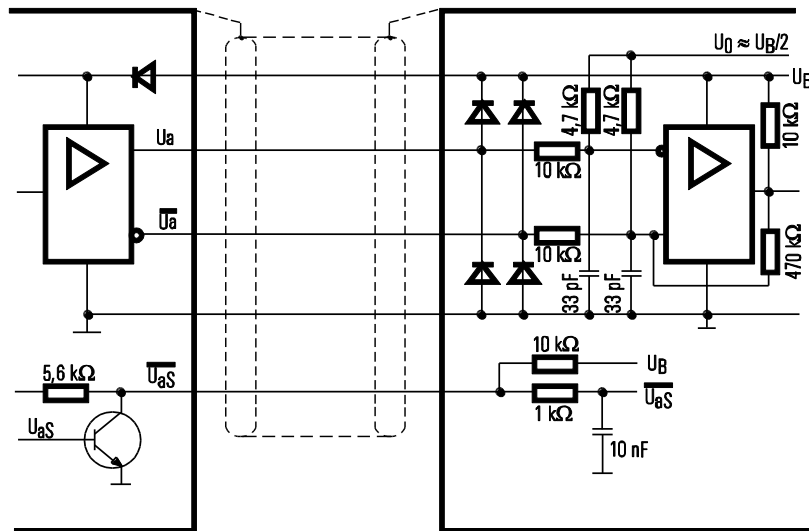

Output signals

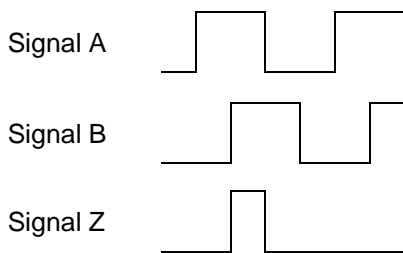

Absolute encoder outputs

Signal conditioner HSSI

Absolute encoder synchronous serial 	Excitation voltage	10 ... 30 V DC
	Excitation current	100 mA
	Interface	Standard-SSI
	Lines / drivers	Clock and data / RS422
	Code	Gray
	Resolution	12 + 12 bit
	3 dB cutoff frequency	500 kHz
	Control input	$\overline{\text{DIRECTION}}$
	Preset key	Zero adjustment with optical response
	Alarm output	Alarm bit (SSI option), warning bit
	Status LED	Green = OK, red = alarm
	Connection	12 pin male socket

Data format (Mx = Multiturn bits, Sx = Singleturn bits)

Resolution	Clock													
	T1	T2	T3	...	T12	T13	...	T21	T22	T23	T24	T25	T26	
	Data bits													
24 Bit	M11	M10	M09	...	M0	S11	...	S3	S2	S1	S0	0		

Transmission rate

Cable length	Baud rate	Note: Extension of the cable length will reduce the maximum transmission rate.
< 50 m	< 400 kHz	
< 100 m	< 300 kHz	
< 200 m	< 200 kHz	
< 400 m	< 100 kHz	

Signal wiring

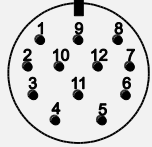
Signal	Connector pin no.	Cable color	View to sensor connector
Excitation +	8	white	 CONN-CONIN-12F
Excitation GND	1	brown	
CLOCK	3	yellow	
$\overline{\text{CLOCK}}$	11	green	
DATA	2	pink	
$\overline{\text{DATA}}$	10	grey	
Direction*	5	blue	
0 V Signal output	12	black	

* unconnected or Excitation + = cw increasing code, 0 V = cw decreasing code

Interface HPROF

Absolute encoder Profibus 	Excitation voltage	10 ... 30 V DC
	Excitation current	250 mA
	Interface	RS485
	Protocol	Profibus DP with encoder profile C2
	Resolution	12 (10 ... 14) + 12 bit
	Output code	Binary
	Baud rate	Automatically selected between 9,6 kBaud and 12 MBaud
	Programmability	Resolution, preset, direction
	Integrated special functions	Velocity, acceleration, operating time
	Bus terminating resistor	Selectable via DIP switch
	Connection	Bus cover with T manifold
	EMC	Din EN 61326: Class A

Signal wiring

Signal	Cable terminal no. (bus cover)
U _b in	1
0 V in	2
U _B out	3
0 V out	4
B in	5
A in	6
B out	7
A out	8

Interface HINT

Absolute encoder Interbus 	Excitation voltage	10 ... 30 V DC
	Excitation current	250 mA
	Interface	Interbus, ENCOM profile K3 (configurable), K2
	Output code	32 Bit binary
	Baud rate	500 kBaud
	Data refresh	Every 600 µs
	Resoution	12 (10 ... 14) + 12 bit
	Programmability	Direction, preset, offset, resolution
	Connection	Bus cover with T manifold
	EMC	DIN EN 61326-1:2013

Data format K2 / K3

	Differential signals (RS485) ENCOM profile K3, K2, 32 Bit, binary process data				
DÜ-Format	Süpi-Adresse	0	1	2	3
(according to the Phoenix company)	Byte no.	3	2	1	0
ID-Code K2	36H (=54 dez.)				
ID-Code K3	37H (=55 dez.)				

Signal wiring

Signal	Cable terminal no. (bus cover)
U _b +	1
GND	2
DI1	4
$\overline{DI1}$	6
D01	3
$\overline{D01}$	5
D02	7
$\overline{D02}$	8
DI2	9
$\overline{D02}$	10
RBST	11
GND	12

Interface HDEV

Absolute encoder DeviceNet 	Excitation voltage	10 ... 30 V DC
	Excitation current	250 mA
	Interface	CAN highspeed according to ISO/DIS 11898 CAN specification 2.0 A (11 bit identifier)
	Protocol	DeviceNet according rev. 2.0, programmable encoder
	Resolution	12 (10 ... 14) + 12 bit
	Output code	Binary
	MAC-ID	Selectable via DIP switch
	Date refresh	Every 5 ms
	Baud rate	Selectable via DIP switch: 125 kBaud, 250 kBaud, 500 kBaud
	Programmability	Resolution, preset, direction
	Bus terminating resistor	Selectable via DIP switch
	Connection	Bus cover with T manifold
	EMC	DIN EN 61326-1:2013

Recommended transmission

Characteristic impedance	135 ... 165 Ω (3 ... 20 MHz)
Operating capacity	< 30 pF
Loop resistance	< 110 Ω/km
Wire diameter	> 0.63 mm
Wire width	> 0.34 mm ²

Transmission rate

Segment length	Kbit/s
500 m	125
250 m	250
100 m	500

Signal wiring

Signal	Cable terminal no. (bus cover)
U _b in	1
0 V in	2
CAN-L	4
CAN-H	6
Drain	3
Drain	5
CAN-H	7
CAN-L	8

Interface HCAN / HCANOP

Absolute encoder CANopen / CAN Layer 2 	Excitation voltage	10 ... 30 V DC
	Excitation current	250 mA
	Interface	CAN highspeed according to ISO/DIS 11898
	Protocol	CANopen according DS301 with encoder profile DSP406, programmable encoder according class C2
	Resolution	12 (10 ... 14) + 12 bit
	Output code	Binary
	Data refresh	Every millisecond (selectable), on request
	Baud rate	Selectable 10 up to 1000 kbit/s
	Base identifier	Selectable via DIP switch
	Programmability	CANopen: direction, resolution, preset, offset CAN L2: direction, limit values
	Integrated special functions	CANopen: velocity, acceleration, rotary axis, limit values CAN L2: direction, limit values
	Connection	Bus cover with T manifold
	EMC	DIN EN 61326-1:2013

Signal wiring

Signal	Cable terminal no. (bus cover)
U _b in	1
0 V in	2
CAN in – (dominant L)	4
CAN in + (dominant H)	6
CAN GND in	3
CAN GND out	5
CAN out + (dominant H)	7
CAN out – (dominant L)	8
0 V out	9
U _b out	10

Accessories

Plug-in connector CONIN, 12 pin (straight coupling)

Order code:

CONN-CONIN-12F-G

Cable diameter
max. 6 ... 8 mm

