



MODEL 4810A ACCELEROMETER

SPECIFICATIONS

- MEMS DC Accelerometer
- Ultra-Stable, DC Response
- Hermetically Sealed
- <2.0% Total Error Band
- <0.1% Linearity Accuracy

The Model 4810A is an ultra-stable MEMS accelerometer packaged in a rugged, low-profile stainless steel housing. The accelerometer is available in ranges from ± 2 to $\pm 200g$ with a wide bandwidth from DC to 2700Hz. The model 4810A accelerometers incorporate gas damped variable capacitance MEMS sensing elements that provide exceptional performance over a full operating temperature range of -55°C to $+125^{\circ}\text{C}$. The accelerometers are designed for 4 to 30Vdc excitation voltage and include a self-test option.

For a triaxial version, TE Connectivity also offers the model 4835A accelerometer.

FEATURES

- $\pm 2g$ to $\pm 200g$ Dynamic Range
- Self-test Enabled
- Amplified Output, Signal Conditioned
- Gas Damped MEMS Sensors
- Hermetically Sealed, Detachable Cable
- 4 to 30Vdc Excitation Voltage
- 6000g Shock Protection

APPLICATIONS

- Flight Testing
- Flutter and Nacelle Vibrations
- Road Vehicle Testing
- Structural Testing
- Test and Instrumentation
- Transportation Applications

PERFORMANCE SPECIFICATIONS

All values are typical at +24°C, 80Hz and 12Vdc excitation unless otherwise stated. TE Connectivity reserves the right to update and change these specifications without notice.

Parameters

DYNAMIC								Notes
Range (g)	±2	±5	±10	±30	±50	±100	±200	
Sensitivity (mV/g)	1000	400	200	67	40	20	10	±5%
Frequency Response (Hz)	0-700	0-1100	0-2000	0-2300	0-2700	0-2700	0-2700	±5%
Non-Linearity (%FSO)	±0.1	±0.1	±0.1	±0.1	±0.1	±0.1	±0.1	
Transverse Sensitivity (%)	<2	<2	<2	<2	<2	<2	<2	<1 Typical
Damping Ratio	0.7	0.7	0.7	0.7	0.7	0.7	0.7	
Shock Limit (g)	6000	6000	6000	6000	6000	6000	6000	
Residual Noise (µV RMS)	360	380	400	440	480	500	500	Passband
Spectral Noise (µg/√Hz)	14	28	45	137	231	464	920	Passband

ELECTRICAL

Zero Acceleration Output (mV)	±50							Differential
Excitation Voltage (Vdc)	4 to 30							
Excitation Current (mA)	<5							
Common Mode Voltage (Vdc)	1.65							
Full Scale Output (differential)	±2 Vpk (FSO=2V)							
Full Scale Output (single-ended)	+0.65 to 2.65 Vpk (FSO=1V)							
Output Resistance (Ω)	<100							
Insulation Resistance (MΩ)	>100							@100Vdc
Turn On Time (msec)	<100							
Ground Isolation	Isolated from Mounting Surface							

ENVIRONMENTAL

Thermal Zero Shift (%FSO/°C)	±0.004							Typical
Thermal Sensitivity Shift (%/°C)	±0.008							Typical
Operating Temperature (°C)	-55 to 125							
Storage Temperature (°C)	-55 to 125							
Humidity	Hermetically Sealed, IP67 ¹							
Total Error Band	<2% (RSS of Non-Linearity, Thermal Zero Shift, and Thermal Sensitivity Shift)							

PHYSICAL

Case Material	Stainless Steel
Weight (grams)	16
Mounting	2x #4 or M3 Screws
Mounting Torque	6 lb-in (0.7 N-m)

¹ Mating cable needs to also have minimum IP67 rating and be properly sealed to accel connector in accordance with IEC 60529.

Calibration supplied:	CS-FREQ-0100	NIST Traceable Amplitude Calibration from 20Hz to ±5% Frequency Response Limit
Supplied accessories:	AC-A02285	2x #4-40 (7/16 length) Socket Head Cap Screw and Washer
Optional accessories:	AC-D02669 341A-120 121	Triaxial Mounting Block Cable Assembly, #30 AWG, -54 to +121°C (5ft standard) 3-Channel Precision Low Noise DC Amplifier

The information in this sheet has been carefully reviewed and is believed to be accurate; however, no responsibility is assumed for inaccuracies. Furthermore, this information does not convey to the purchaser of such devices any license under the patent rights to the manufacturer. TE Connectivity reserves the right to make changes without further notice to any product herein. TE Connectivity makes no warranty, representation or guarantee regarding the suitability of its product for any particular purpose, nor does TE Connectivity assume any liability arising out of the application or use of any product or circuit and specifically disclaims any and all liability, including without limitation consequential or incidental damages. Typical parameters can and do vary in different applications. All operating parameters must be validated for each customer application by customer's technical experts. TE Connectivity does not convey any license under its patent rights nor the rights of others.

MODEL 4810A ACCELEROMETER

DIMENSIONS

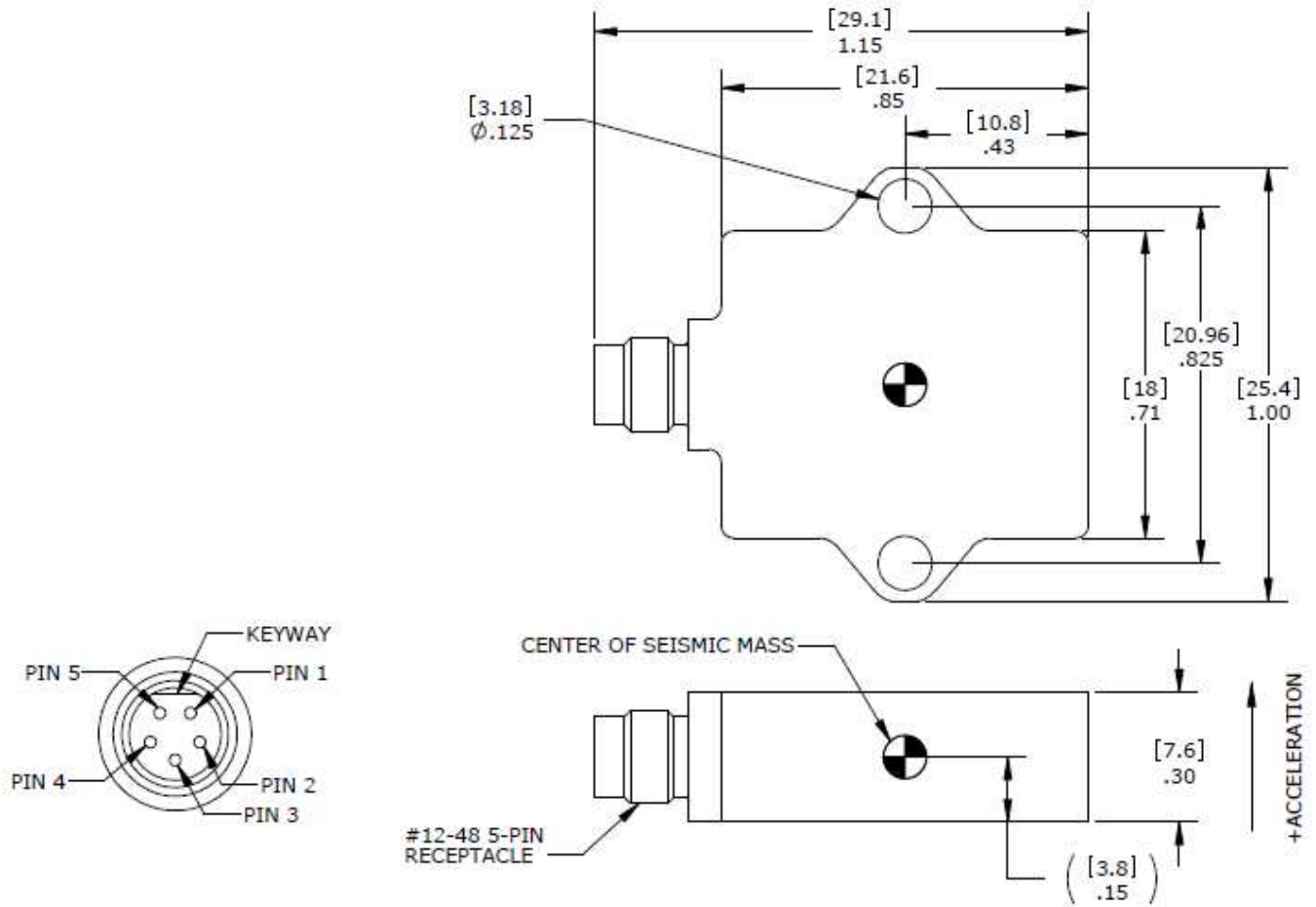

SCHEMATIC

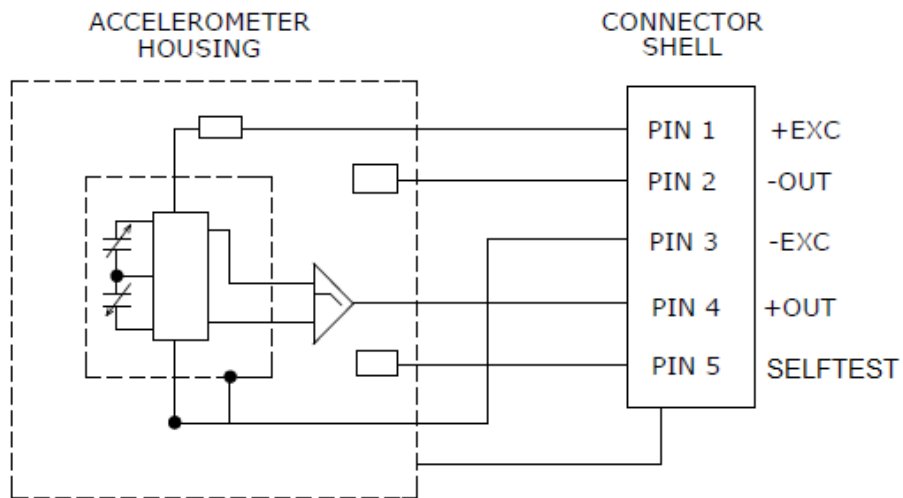

ORDERING INFORMATION

Part Number	Range
4810A-0002-D	2g
4810A-0005-D	5g
4810A-0010-D	10g
4810A-0030-D	30g
4810A-0050-D	50g
4810A-0100-D	100g
4810A-0200-D	200g

NORTH AMERICA

Measurement Specialties, Inc.,
a TE Connectivity Company
Tel: 800-522-6752
customercare.hmpt@te.com

EUROPE

MEAS France SAS
a TE Connectivity Company
Tel: +31 73 624 6999
customercare.lcsb@te.com

ASIA

Measurement Specialties (China), Ltd.,
a TE Connectivity Company
Tel: 0400-820-6015
customercare.shzn@te.com

TE.com/sensorsolutions

MEAS France SAS and Measurement Specialties (China), Inc., are TE Connectivity companies.

TE Connectivity, TE, TE connectivity (logo) are trademarks. All other logos, products and/or company names referred to herein might be trademarks of their respective owners.

The information given herein, including drawings, illustrations and schematics which are intended for illustration purposes only, is believed to be reliable. However, TE Connectivity makes no warranties as to its accuracy or completeness and disclaims any liability in connection with its use. TE Connectivity's obligations shall only be as set forth in TE Connectivity's Standard Terms and Conditions of Sale for this product and in no case will TE Connectivity be liable for any incidental, indirect or consequential damages arising out of the sale, resale, use or misuse of the product. Users of TE Connectivity products should make their own evaluation to determine the suitability of each such product for the specific application.

© 2017 TE Connectivity Ltd. All Rights Reserved.