

- Elevate caratteristiche metrologiche verificate presso l' Istituto Nazionale di Ricerca Metrologica (I.N.R.I.M.).
- Elevata stabilità grazie alla struttura monolitica.
- Struttura ottimizzata mediante progettazione ad elementi finiti.
- Compensazione ai carichi fuori asse $\leq 0.005\%$ F.S.
- Bassa sensibilità ai piani di appoggio $\leq 0.002\%$ F.S.
- Facile applicazione a trazione e compressione.
- Maneggevole grazie al peso ridotto (1MN ~36kg).

- *Excellent metrological features stated by the Metrological Research National Institute (I.N.R.I.M.).*
- *High stability given by monolithic structure.*
- *Structure optimization thanks to the F.E.M. design.*
- *Off-center loads compensation $\leq 0.005\%$ F.S.*
- *Low sensitivity to supporting surfaces $\leq 0.002\%$ F.S.*
- *Easy application for tension and compression.*
- *Easy to handle thanks to its light weight (1MN ~36kg).*

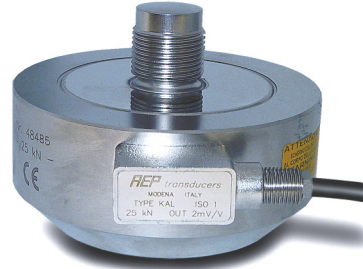

Linearità - Isteresi
 $\leq \pm 0.02\%$
 Linearity - Hysteresis

Accessori Accessories



Certificato di Taratura ACCREDIA
A RICHIESTA

LAT N° 093
Calibration Centre
 The products are NOT covered by accreditation

ACCREDIA Calibration Certificate
ON REQUEST

Dimensioni Dimensions

[mm]

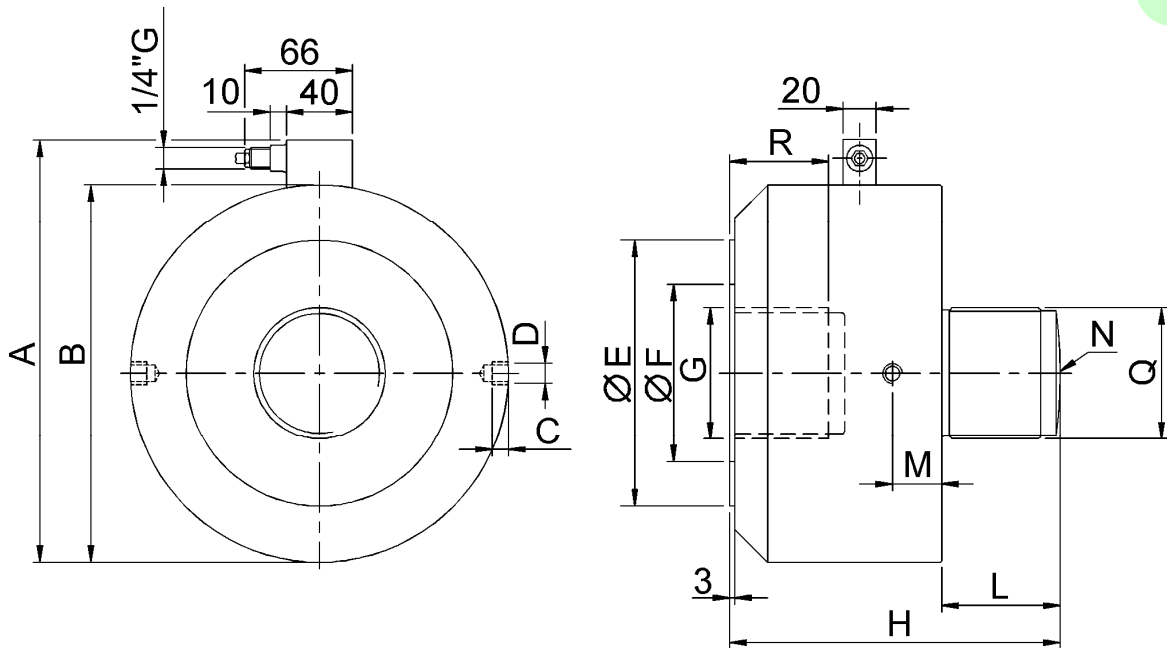

CODE (class 00)	CODE (class 0.5)	CODE (class 1)	LOAD	A	B	C	D	ØE	ØF	G	H	L	M	N	Q	R
CKAL12710KN005	CKAL12710KN055	CKAL12710KN15	10 kN													
CKAL12725KN005	CKAL12725KN055	CKAL12725KN15	25 kN	152	127	12	M8	84	61	M42X3	91	33	10	R65	M30X2	20
CKAL12750KN005	CKAL12750KN055	CKAL12750KN15	50 kN													
⁽¹⁾ CKAL165100KN005	⁽¹⁾ CKAL165100KN055	⁽¹⁾ CKAL165100KN15	100 kN													
⁽¹⁾ CKAL165200KN005	⁽¹⁾ CKAL165200KN055	⁽¹⁾ CKAL165200KN15	200 kN	190	165	20	M10	112	71	M56X3	114 135	42	12	R160	M42X3	31
⁽¹⁾ CKAL165300KN005	⁽¹⁾ CKAL165300KN055	⁽¹⁾ CKAL165300KN15	300 kN													
⁽¹⁾ CKAL230500KN005	⁽¹⁾ CKAL230500KN055	⁽¹⁾ CKAL230500KN15	500 kN													
⁽¹⁾ CKAL230750KN005	⁽¹⁾ CKAL230750KN055	⁽¹⁾ CKAL230750KN15	750 kN	255	230	24	M12	162	101	M80X2	179 201	72	15	R300	M80X2	46
⁽¹⁾ CKAL2301MN005	⁽¹⁾ CKAL2301MN055	⁽¹⁾ CKAL2301MN15	1000 kN													

⁽¹⁾ La taratura ACCREDIA NON può essere eseguita dal Centro LAT N° 093, a richiesta può essere commissionata ad altri Centri di taratura accreditati.
 ACCREDIA certification can NOT be performed by LAT n° 93 Laboratory, on request it can be ordered to other Accredited Laboratories.

I trasduttori di questa serie si distinguono per elevate caratteristiche metrologiche, stabilità a lungo termine e insensibilità a carichi fuori asse.

Nate dall'esigenza di stimare le incertezze tra le diverse macchine campioni di forza dei centri ACCREDIA e i campioni nazionali, oggi vengono impiegati come Campioni di Prima linea o di trasferimento tra Laboratori, enti di ricerca, e aziende che lavorano in regime di Qualità. Grazie alle dimensioni ridotte e alla facilità di montaggio vengono applicati, come sistema di riferimento, su macchine campioni di forza, macchine prova materiali e banchi prova.

The transducers belonging to these series distinguish themselves for their excellent metrological characteristics, long-term stability and insensitivity to off-center loads.

Born from the need of estimating the uncertainties among force sample machines of ACCREDIA centers and national samples, these dynamometers are nowadays used as first line or transfer samples among laboratories, research bodies and companies working according to Quality standards. Thanks to their compact size and easy installation, they are applied as reference system, on force sampling machines, materials testing machines and test benches.

Dati Tecnici Technical Data



Classe di precisione ISO 376	Accuracy class ISO 376	00	0.5	1
CARICO NOMINALE	NOMINAL LOAD	10-25-50-100-200-300-500-750-1000 kN		
ERRORI RELATIVI (al valore letto)	RELATIVE ERROR (at reading)			
a) ripetibilità 0°-120°-240° (b)	a) repeatability 0°-120°-240° (b)	≤ ±0.020% ⁽¹⁾	≤ ±0.045% ⁽¹⁾	≤ ±0.080% ⁽¹⁾
b) interpolazione (fc)	b) interpolation (fc)	≤ ±0.020% ⁽¹⁾	≤ ±0.040% ⁽¹⁾	≤ ±0.050% ⁽¹⁾
c) reversibilità (u)	c) reversibility (u)	≤ ±0.030% ⁽¹⁾	≤ ±0.050% ⁽¹⁾	≤ ±0.090% ⁽¹⁾
d) zero (fo)	d) zero (fo)	≤ ±0.005% F.S.	≤ ±0.010% F.S.	≤ ±0.010% F.S.
LINEARITA'	LINEARITY		≤ ±0.02% F.S.	
ISTERESI	HYSTERESIS		≤ ±0.02% F.S.	
EFFETTO DELLA TEMPERATURA (10°C)	TEMPERATURE EFFECT (10°C)			
a) sullo zero	a) on zero		≤ ±0.015% F.S.	
b) sulla sensibilità	b) on sensitivity		≤ ±0.010% F.S.	
SENSIBILITA' NOMINALE	NOMINAL SENSITIVITY		2mV/V	
TOLLERANZA DI CALIBRAZIONE	SENSIVITY TOLERANCE		≤ ±0.1% F.S.	
CARICO NOMINALE	NOMINAL LOAD		10-25-50kN	
RESISTENZA DI INGRESSO	INPUT RESISTANCE		700±2Ω	
RESISTENZA DI USCITA	OUTPUT RESISTANCE		705±2Ω	
CARICO NOMINALE	NOMINAL LOAD		100-200-300-500-750-1000kN	
RESISTENZA DI INGRESSO	INPUT RESISTANCE		350±2Ω	
RESISTENZA DI USCITA	OUTPUT RESISTANCE		352±2Ω	
RESISTENZA DI ISOLAMENTO	INSULATION RESISTANCE		> 5 GΩ	
BILANCIAMENTO DI ZERO	ZERO BALANCE		≤ ±0.2 % F.S.	
ALIMENTAZIONE DI RIFERIMENTO	RECOMMENDED SUPPLY VOLTAGE		10 V	
ALIMENTAZIONE NOMINALE	NOMINAL SUPPLY VOLTAGE		1-15 V	
ALIMENTAZIONE MAX.	MAXIMUM SUPPLY VOLTAGE		18 V	
VALORI MECCANICI LIMITE RIFERITI AL CARICO NOMINALE :	MECHANICAL LIMIT VALUES REFERRED TO NOMINAL LOAD :			
a) carico di servizio	a) service load		120%	
b) carico limite	b) max permissible load		150%	
c) carico di rottura	c) breaking load		>300%	
d) massimo carico trasversale	d) max transverse load		100%	
e) carico dinamico limite	e) max permissible dynamic load		75%	
FRECCIA MAX. AL CARICO NOMINALE	DISPLACEMENT AT NOMINAL LOAD		~ 0.2 mm	
TEMPERATURA DI RIFERIMENTO	REFERENCE TEMPERATURE		+23°C	
CAMPO NOMINALE DI TEMPERATURA	TEMPERATURE NOMINAL RANGE		-10/+40 °C	
TEMPERATURA DI ESERCIZIO	SERVICE TEMPERATURE		-10/+70 °C	
TEMPERATURA DI STOCCAGGIO	STORAGE TEMPERATURE		-20/+80 °C	
PESO	WEIGHT		~ 4.5 - 36 kg	
CLASSE DI PROTEZIONE (EN 60529)	PROTECTION CLASS (EN 60529)		IP67	
MATERIALE DINAMOMETRO	EXECUTION MATERIAL		Acciaio Inox / Stainless Steel	
LUNGHEZZA CAVO	CABLE LENGTH		5m	

⁽¹⁾ Errori percentuali calcolati al valore letto, min. 1/10 del carico nominale. / Percentage errors referred to reading, min. 1/10 of the nominal load.

⁽²⁾ Test e calibrazioni eseguite in **COMPRESSIONE**. / Tests and calibrations performed in **COMPRESSION**.

A richiesta calibrazioni in kg. / kg calibrations on request.

A richiesta classificazioni secondo **ASTM E74**. / Classifications according **ASTM E74** on request.

Collegamenti Elettrici Electrical Connections

Cavo schermato PVC 105°C, Ø 5.2mm a 6 conduttori Ø 0.25mm² stagnati.

PVC 105°C shielded cable, Ø 5.2mm with 6 tinned Ø 0.25mm² conductors.

Transducer	OUTPUT	CABLE	CAVO	MIL7M (optional)
	EXCITATION+ SENSE+ OUTPUT+ EXCITATION - SENSE- OUTPUT- -----	<i>Red</i> <i>Orange</i> <i>White</i> <i>Black</i> <i>Blue</i> <i>Yellow</i> <i>Shield*</i>	Rosso Arancione Bianco Nero Blu Giallo Schermo*	C F A B G D E

* Collegato al corpo del trasduttore. / Connected to the body of the transducer..

Applicazioni industriali

Industrial applications

COMPRESSIONE *COMPRESSION*

TRAZIONE *TENSION*

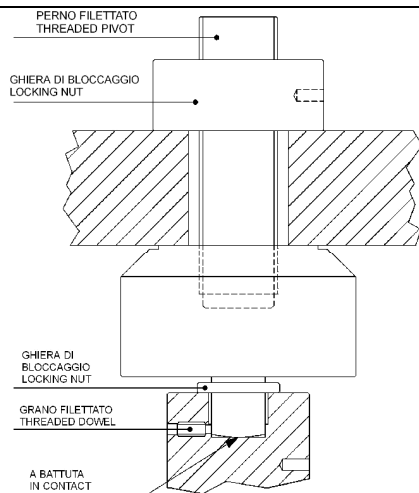
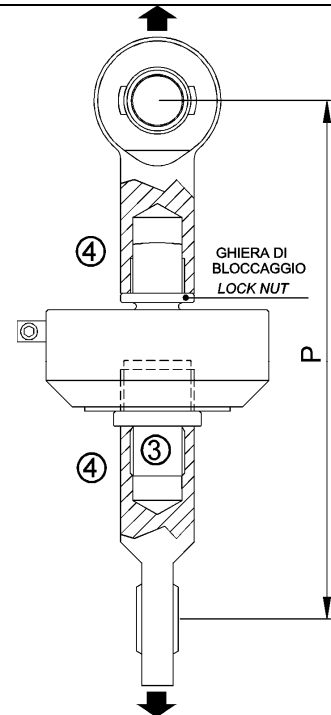
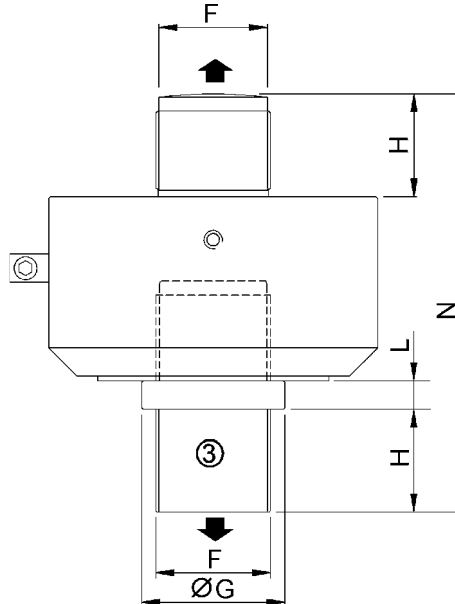
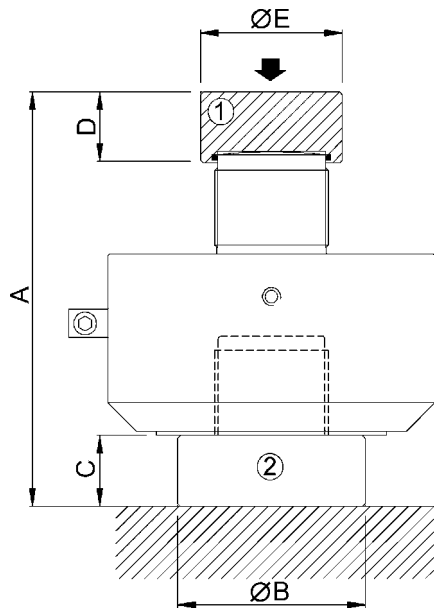

ATTENZIONE

Verificare che gli accessori siano correttamente serrati.

Materiale accessori:
da 10 a 200 kN
Da 300 a 1000 kN

Acciaio inox
Rm ≥ 90 kg/mm²
Rm ≥ 130 kg/mm²

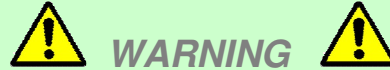

WARNING

Check that accessories are correctly tightened.

Accessories material:
from 10 to 200 kN
from 300 to 1000 kN

Stainless Steel
Rm ≥ 90 kg/mm²
Rm ≥ 130 kg/mm²

Dimensioni *Dimensions*

[mm]

KAL:	A	ØB	C	D	ØE	F	ØG	H	L	N	P
5, 10, 25, 50 kN	142	65	25	30	57	M30X2	50	33	10	134	~ 295
100 kN	182	100	34	38	76	M42X3	62	42	10	166	~ 380
200, 300 kN	203									187	~ 400
500 kN	272	127	50	50	100	M80X2	100	72	20	271	/
750 kN	294									293	/
1000 kN	297									296	/

Accessori *Accessories*

KAL:	CODE	ACCESSORIES (optional):	ACCESSORI (opzionali):
10, 25, 50 kN	CTIC127KAL	① Loading head.	Testa di carico.
	CBC127KAL	② Mounting plate.	Piastra base.
	CAT127KAL	③ Tension screw.	Vite di trazione.
	CACCEF30	④ Knuckle joint. (static applications)	Teste a snodo sferico. (applicazioni statiche)
100, 200, 300 kN	CTIC165KAL	① Loading head.	Testa di carico.
	CBC165KAL	② Mounting plate.	Piastra base.
	CAT165KAL	③ Tension screw.	Vite di trazione.
100, 200 kN	CACCEF40	④ Knuckle joint. (static applications)	Teste a snodo sferico. (applicazioni statiche)
500, 750, 1000 kN	CTIC230KAL	① Loading head.	Testa di carico.
	CBC230KAL	② Mounting plate.	Piastra base.
	CAT230KAL	③ Tension screw.	Vite di trazione.

Applicazioni in accordo alla UNI EN ISO 376
Applications according to UNI EN ISO 376

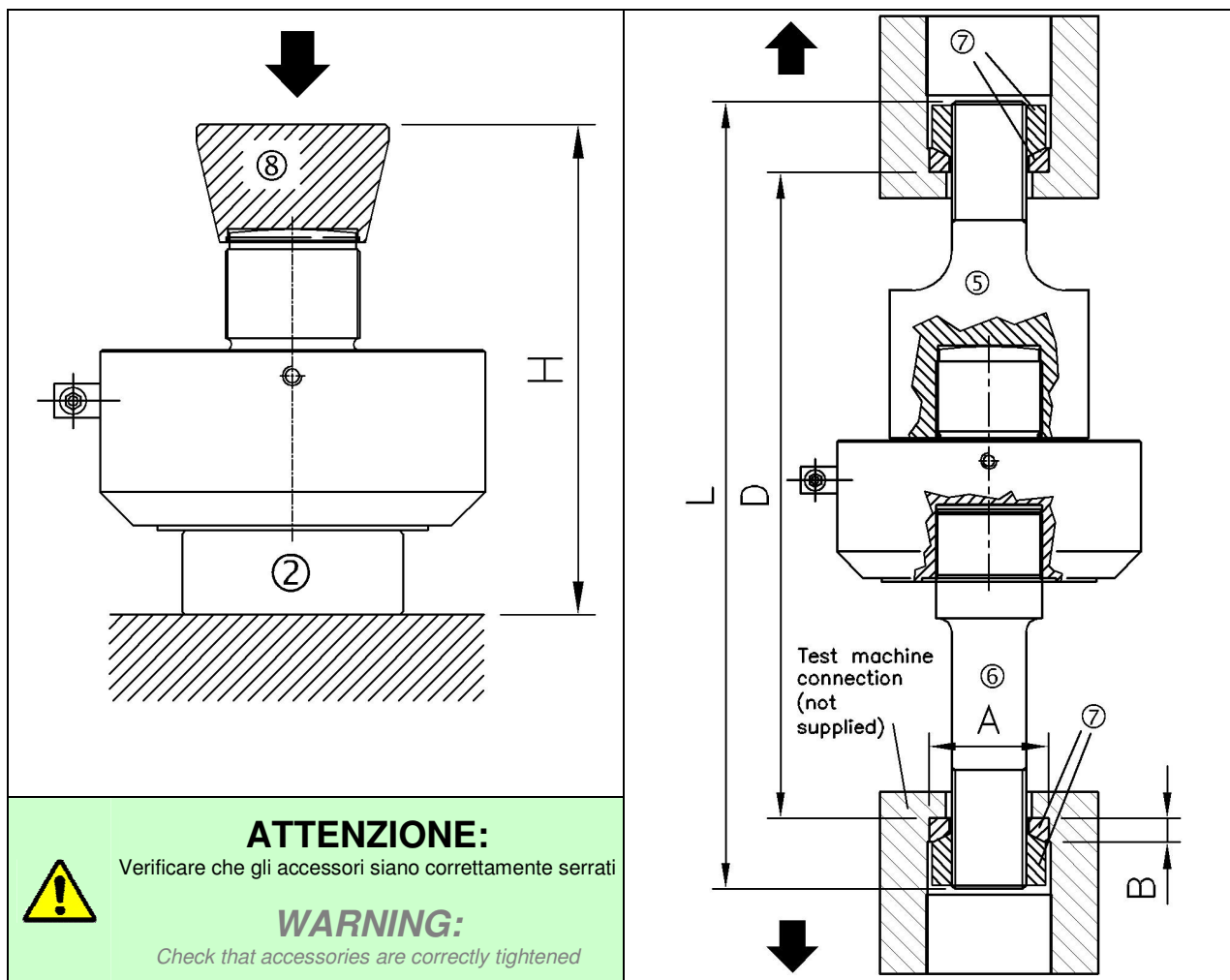

ATTENZIONE:

Verificare che gli accessori siano correttamente serrati

WARNING:

Check that accessories are correctly tightened



Accessori Accessories

KAL:	Dimensioni <i>Dimensions</i> [mm]						Codici <i>Codes</i>	
	L	D		A (c11)	B	H	<i>Tension set</i> (5+7) + (6+7)	<i>Compression head</i> 8
Min		Max						
10, 25 kN	~317	210	266	35	12	146	CTISO25A + CTISO25B	CCISO50
50 kN	~346	257	294	45	15	146	CTISO50A + CTISO50B	
100 kN	~394	264	332	50	15	193	CTISO100A + CTISO100B	CCISO300
200 kN	~445	302	380	64	15	214	CTISO200A + CTISO200B	
300 kN	~494	308	397	90	18	214	CTISO300A + CTISO300B	CCISO500
500 kN	~595	395	493	90	18	292	CTISO500A + CTISO500B	
750KN, 1MN	~616	413	472	120	25	339	CTISO1MA + CTISO1MB	CCISO1M
	~619	416	475			342		



41126 Cognento (MODENA) Italy Via Bottego 33/A Tel:+39-(0)59-346441 Fax:+39-(0)59-346437 E-mail: aep@aep.it

Al fine di migliorare le prestazioni tecniche del prodotto, la società si riserva di apportare variazioni senza preavviso.
In order to improve the technical performances of the product, the company reserves the right to make any change without notice.