

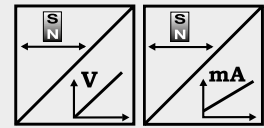

POSICHRON® position sensor in square profile

- Protection class IP64
- Measurement range 0 ... 100 to 0 ... 5750 mm
- Absolute position measurement
- Easy installation with mounting brackets
- Wear free position magnet
- Contactless
- Also available with guided position magnet
- Analog outputs



Specifications	Output	Voltage Current
	Resolution	Refer to output specification
Sampling rate	Up to 1 kHz, depending on the measurement range	
Linearity	Ranges >500 mm: L10 = ±0.10 % f.s. L02 = ±0.02 % f.s. Ranges ≤500 mm: L10 = ±0.5 mm L02MM = ±0.2 mm	
Repeatability	±3 µm	
Housing material	AlMgSi1 / Zn / V4A	
Protection class	IP64 (connector version: with mating connector only)	
Shock	EN 60068-2-27:2010, 50 g 11 ms, 100 shocks	
Vibration	EN 60068-2-6:2008, 20 g 10 Hz-2 kHz, 10 cycles	
Connection	Connector M12, 8 pin / cable 2 m	
EMC, temperature	Refer to output specification	

**Order code PCQA22
1 channel**



Model name

Measurement range (in mm)

100 ... 5750 (in 10 mm increments)
other lengths upon request

Output

- U1 = 0 ... 10 V signal conditioner
- U1/H = U1 with Alarm_HOLD (see page 11)
- U2 = 0.5 ... 10 V signal conditioner
- U2/U; U2/H = U2 with Alarm_LOW; U2 with Alarm_HOLD (see page 11)
- U8 = 0.5 ... 4.5 V signal conditioner
- U8/U; U8/H = U8 with Alarm_LOW; U8 with Alarm_HOLD (see page 11)
- I1 = 4 ... 20 mA signal conditioner (3 wire)
- I1/U; I1/H = I1 with Alarm_LOW; I1 with Alarm_HOLD (see page 11)

Function and characteristics output

- P1A = Position Magnet 1, increasing
- P1D = Position Magnet 1, decreasing
- PMU = Start value, direction & end value adjustable by the customer

Linearity

L02 / L02MM / L10 (for definition see "Specifications" above)

Connection

- M12 = Connector M12, 8 pin
- KAB2M = Cable, standard length 2 m, other lengths upon request

Order code mounting set (see page 7)

PCQA-BFS1

Order Code PCQA22

**2 channel,
configurable**

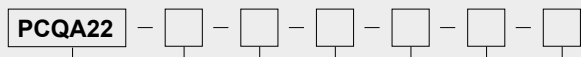

Model name

Measurement range (in mm)

100 ... 5750 (in 10 mm increments)
other lengths upon request

Output

- U1 = 0 ... 10 V signal conditioner
- U1/H = U1 with Alarm_HOLD (see page 11)
- U2 = 0.5 ... 10 V signal conditioner
- U2/U; U2/H = U2 with Alarm_LOW; U2 with Alarm_HOLD (see page 11)
- U8 = 0.5 ... 4.5 V signal conditioner
- U8/U; U8/H = U8 with Alarm_LOW; U8 with Alarm_HOLD (see page 11)
- I1 = 4 ... 20 mA signal conditioner (3 wire)
- I1/U; I1/H = I1 with Alarm_LOW; I1 with Alarm_HOLD (see page 11)

Function and characteristics output 1

- P1A = Position magnet 1, increasing
- P1D = Position magnet 1, decreasing
- DA = Difference magnet 1/2, increasing (2 magnets required)
- DD = Difference magnet 1/2, decreasing (2 magnets required)

Function and characteristics output 2

- P2A = Position magnet 2, increasing
 - P2D = Position magnet 2, decreasing
 - DA = Difference magnet 1/2, increasing
 - DD = Difference magnet 1/2, decreasing
- } 2 magnets required

VZx.x = Velocity with direction detection (with 1 magnet only)

VZx.x = Velocity in steps of 0.1 m/s			
<u>Example: VZ1.5</u> towards start position			
	-1.5 m/s	0	towards end position +1.5 m/s
Output U2:	0.5 V	5.25 V	10 V
Output I1:	4 mA	12 mA	20 mA

VAx.x = Velocity without direction detection (with 1 magnet only)

VAx.x = Velocity in steps of 0.1 m/s			
<u>Example: VA1.5</u> towards start position			
	-1.5 m/s	0	towards end position +1.5 m/s
Output U2:	10 V	0.5 V	10 V
Output I1:	20 mA	4 mA	20 mA

Linearity

L02 / L02MM / L10 (for definition see "Specifications" above)

Connection

- M12 = Connector M12, 8 pin
- KAB2M = Cable, standard length 2 m, other lengths upon request

1. Order example: PCQA22 - 1000 - I1 - P1A - P2D - L10 - M12

Square profile, measurement range 1000 mm, 2 current outputs 4 ... 20 mA (I1)

Output 1: Position magnet 1, increasing signal (P1A)

Output 2: Position magnet 2, decreasing signal (P2D)

2. Order example: PCQA22 - 1000 - U2 - P1A - VZ1.0 - L10 - M12

Square profile, measurement range 1000 mm, 2 voltage outputs 0.5 ... 10 V (U2)

Output 1: Position magnet 1, increasing signal (P1A)

Output 2: Velocity magnet 1, -1 m/s ... 1 m/s for range 0.5 ... 10 V (VZ1.0)

Order code position magnet/slider (see page 8)

PCMAG ...

Order code mating connecting cable (see page 15)

KAB-...M-M12/8F/G-LITZE



POSICHRON® position sensor in square profile

- Protection class IP64
- Measurement range 0 ... 100 to 0 ... 5750 mm
- Absolute position measurement
- Easy installation with mounting brackets
- Wear free position magnet
- Contactless
- Also available with guided position magnet
- Synchronous serial interface (SSI)

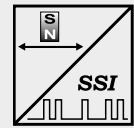

Specifications	Output	Synchronous serial interface (SSI)
	Resolution	5, 10, 20, 50, 100 µm
	Sampling rate	Up to 500 Hz depending on the measurement range
	Linearity	Ranges >500 mm: L10 = ±0.10 % f.s. L02 = ±0.02 % f.s. Ranges ≤500 mm: L10 = ±0.5 mm L02MM = ±0.2 mm
	Repeatability	±3 µm
	Housing material	AlMgSi1 / Zn / V4A
	Protection class	IP64 (connector version: with mating connector only)
	Shock	EN 60068-2-27:2010, 50 g 11 ms, 100 shocks
	Vibration	EN 60068-2-6:2008, 20 g 10 Hz-2 kHz, 10 cycles
	Connection	Connector M12, 8 pin / cable 2 m
EMC, temperature	Refer to output specification	

Order Code PCQA22

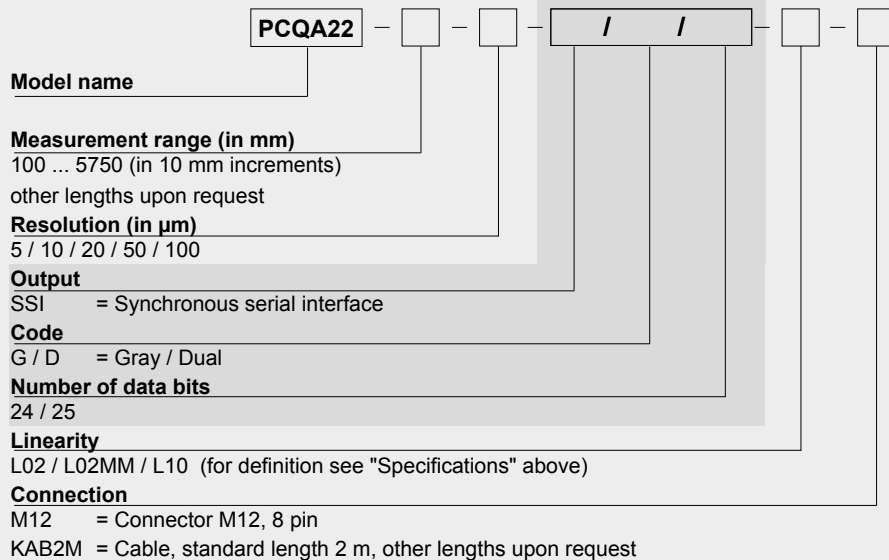

Order code mounting set (see page 7)

PCQA-BFS1

Order code position magnet/slider (see page 8)

PCMAG ...

Order code mating connecting cable (see page 15)

KAB-...M-M12/8F/G-LITZE

Order example: PCQA22 - 2500 - 5 - SSI/G/24 - L10 - M12



POSICHRON® position sensor in square profile

- Protection class IP64
- Measurement range 0 ... 100 to 0 ... 5750 mm
- Absolute position measurement
- Easy installation with mounting brackets
- Wear free position magnet
- Contactless
- Also available with guided position magnet
- CANopen bus or CAN SAE J1939 output

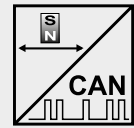

Specifications	Output	CANopen bus; CAN SAE J1939
	Resolution	50 µm
	Sampling rate	Up to 1 kHz, depending on the measurement range
	Linearity	Ranges >500 mm: L10 = ±0.10 % f.s. L02 = ±0.02 % f.s. Ranges ≤500 mm: L10 = ±0.5 mm L02MM = ±0.2 mm
	Repeatability	±3 µm
	Housing material	AlMgSi1 / Zn / V4A
	Protection class	IP64 (connector version: with mating connector only)
	Shock	EN 60068-2-27:2010, 50 g 11 ms, 100 shocks
	Vibration	EN 60068-2-6:2008, 20 g 10 Hz-2 kHz, 10 cycles
	Connection	5 pin socket M12
EMC, temperature	Refer to output specification	

Order Code PCQA22

PCQA22 - [] - [] - [] - []

Model name

Measurement range (in mm)

100 ... 5750 (in 10 mm increments)
other lengths upon request

Output

CANOP = CANopen bus
CANOP/R = CANopen-Bus with integrated terminating resistance
CANJ1939 = CAN SAE J1939

Linearity

L02 / L02MM / L10 (for definition see "Specifications" above)

Connection

M12/CAN = Connector M12, 5 pin

Order code mounting set (see page 7)

PCQA-BFS1

Order code position magnet/slider (see page 8)

PCMAG ...

Order code bus cable (see page 16)

KAB-...M-M12/5F/G-M12/5M/G - CAN

Order example: PCQA22 - 2000 - CANOP - L10 - M12/CAN

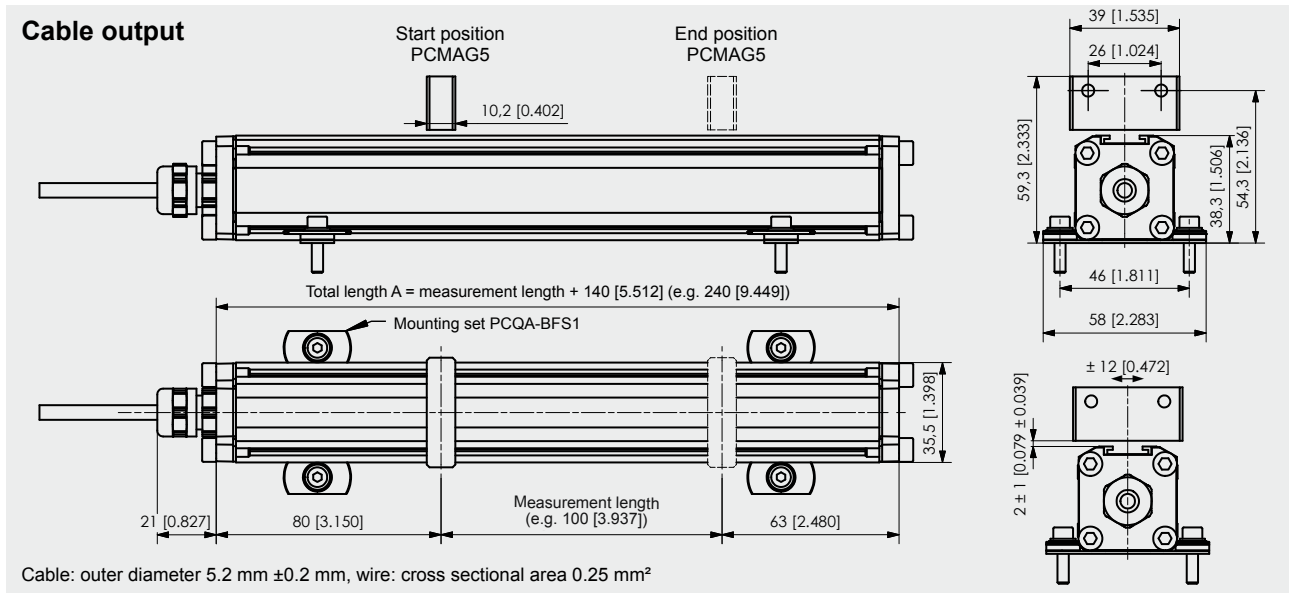

Dimensions in mm [inch]

Dimensions informative only. For guaranteed dimensions consult factory.

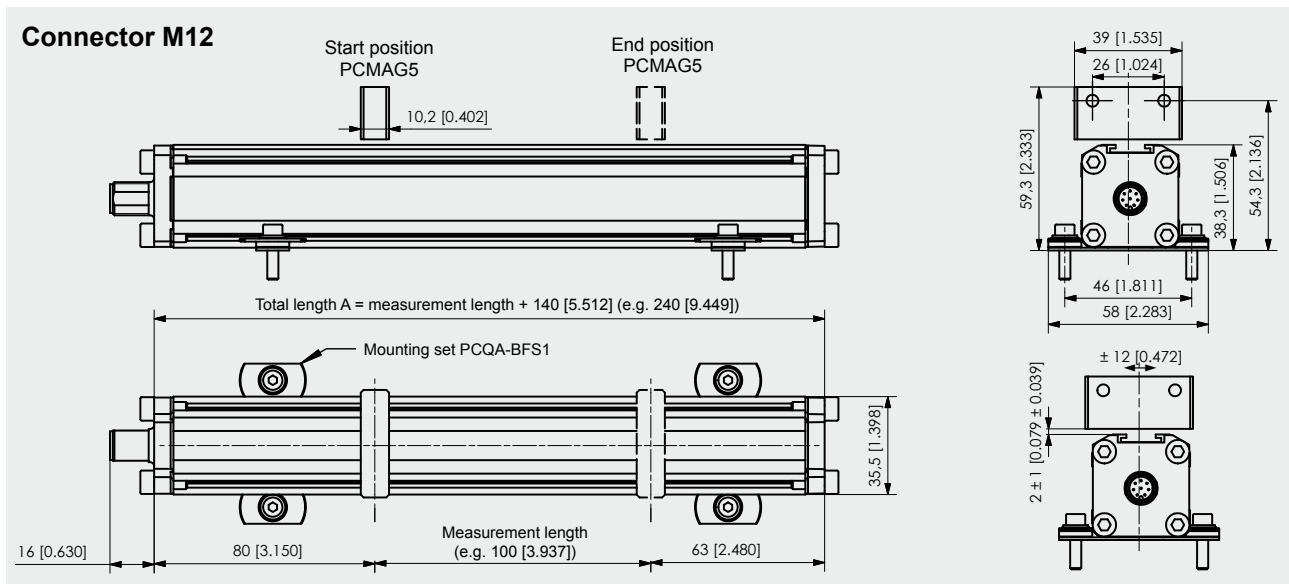

Dimensions in mm [inch]

Dimensions informative only. For guaranteed dimensions consult factory.

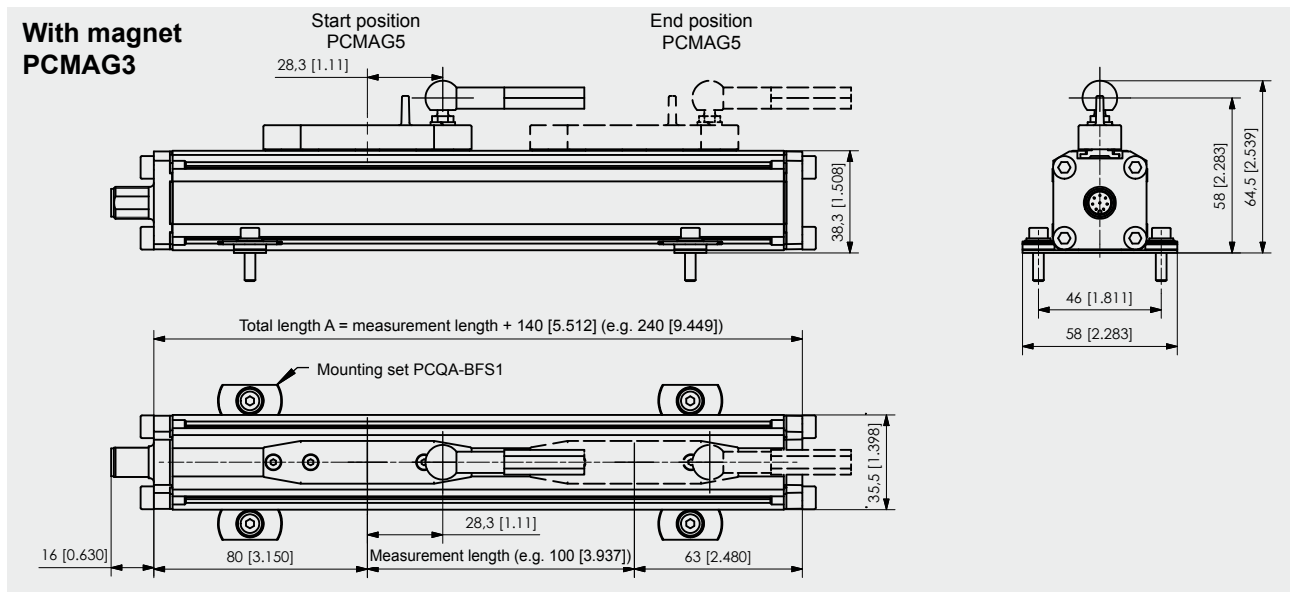

Dimensions in mm [inch]

Dimensions informative only. For guaranteed dimensions consult factory.

**Mounting set
 PCQA-BFS1 with
 mounting clamps**

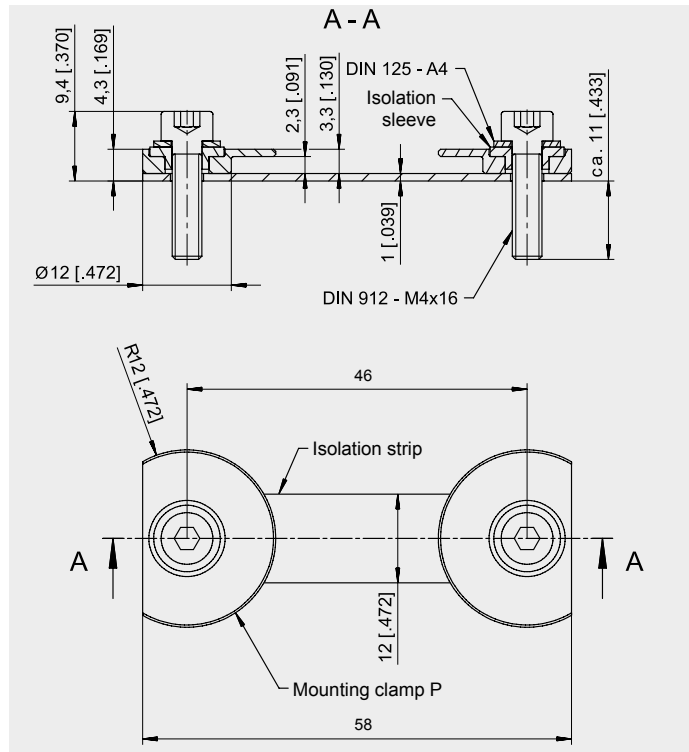

**Option -BFW
 Mounting brackets
 for PCQA22 and
 PCQA24**

Note: The option -BFW can only be ordered with a new sensor, not separately!
 Applicable for sensor lengths up to 1000 mm.

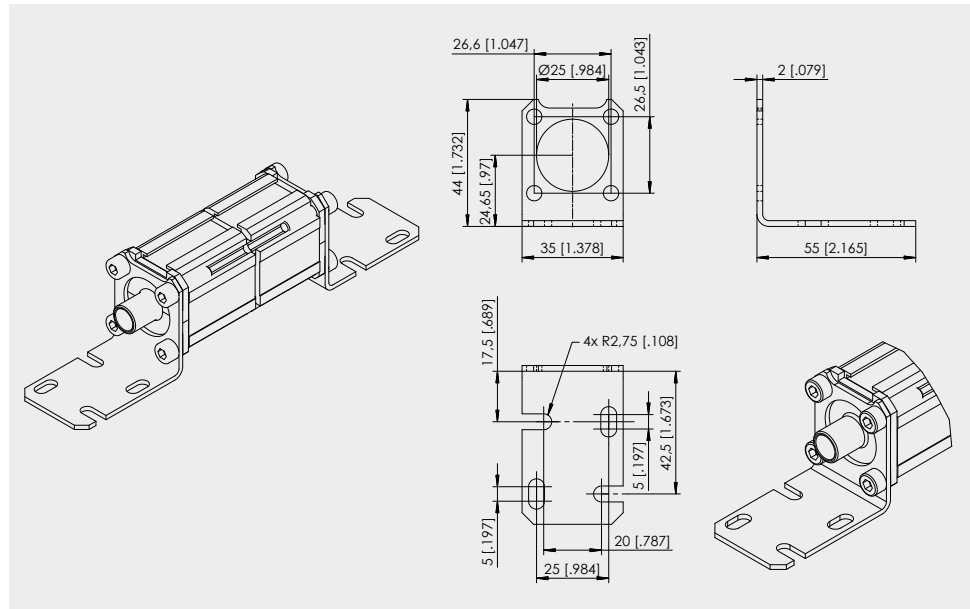

Dimensions in mm [inch]

Dimensions informative only.
 For guaranteed dimensions consult factory.

Order example: PCQA24 - 1000 - U2 - P1A - L10 - M12 - BFW

PCMAG5

Standard magnet

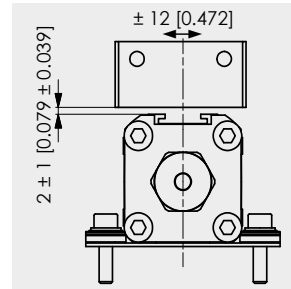
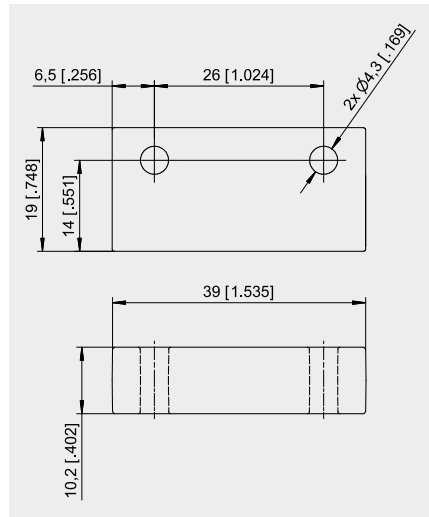

PCMAG3

Guided magnet slider with internal position magnet

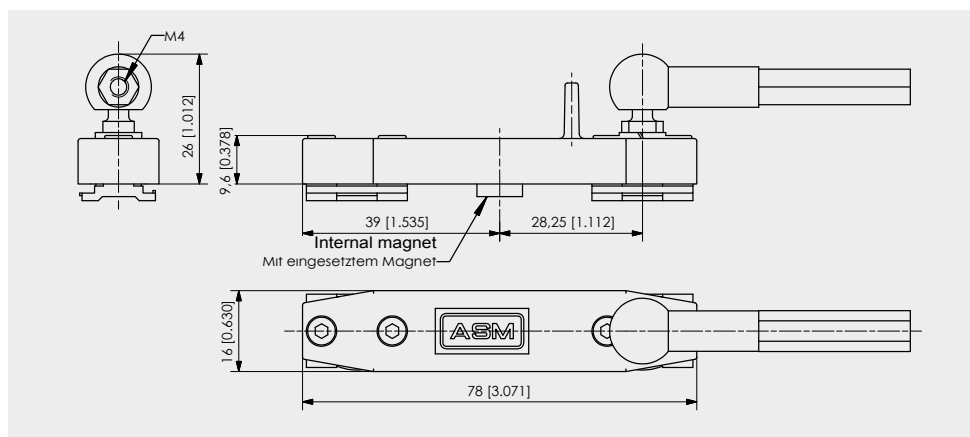

Dimensions in mm [inch]

Dimensions informative only.
For guaranteed dimensions consult factory.

<p>U1, U2, U8 Voltage output</p>	Excitation voltage	U1: 18 ... 36 V DC; U2: 18 ... 36 V DC; U8: 10 ... 36 V
	Excitation current	Typ. 35 mA, 80 mA max.
	Output voltage	U1: 0 ... 10 V DC; U2: 0.5 ... 10 V DC; U8: 0.5 ... 4.5 V DC
	Output current	2 mA max.
	Output load	> 5 kΩ
	Resolution	16 bit f.s., min. 10 μm
	Stability (temperature)	±50 x 10 ⁻⁶ / °C f.s.
	Protection	Reverse polarity, short circuit
	Output noise	0.5 mV _{RMS}
	Operating temperature	-40 ... +85 °C
EMC	EN 61326-1:2013	

Signal diagram

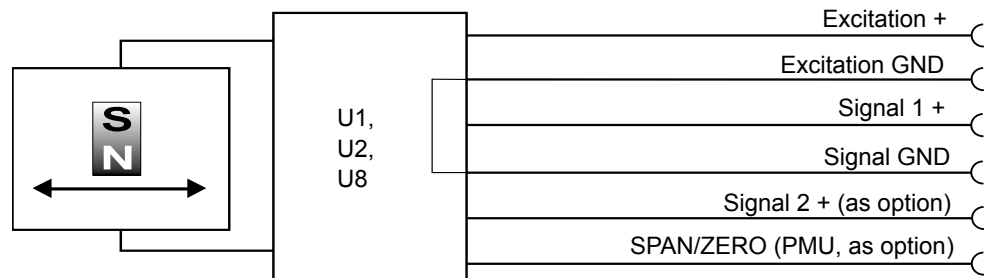

<p>I1 Current output (3 wire)</p>	Excitation voltage	18 ... 36 V DC (10 ... 36 V for R _L ≤ 250Ω)
	Excitation current	Typ. 60 mA, 80 mA max.
	Load resistor	350 Ω max.
	Output current	4 ... 20 mA, 30 mA max (at failure)
	Resolution	16 bit f.s., min. 10 μm
	Stability (temperature)	±50 x 10 ⁻⁶ / °C f.s.
	Protection	Reverse polarity, short circuit
	Output noise	0.5 mV _{RMS}
	Operating temperature	-40 ... +85 °C
	EMC	EN 61326-1:2013

Signal diagram

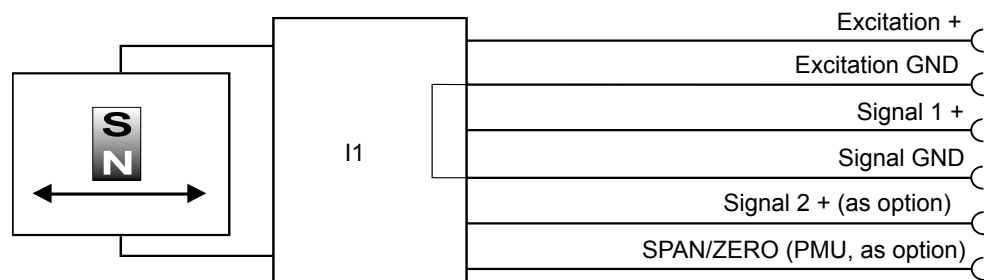

Connector M12, 8-pin

Signal wiring

Signal	Plug connection	Cable connection (not for PCST27, PCRP32!)
Excitation +	1	white
Excitation GND	2	brown
Signal 1 +	3	green
Signal GND	4	yellow
Signal 2 + (optional*)	5	grey
SPAN/ZERO (PMU** only, optional)	6	pink

View to the sensor connector

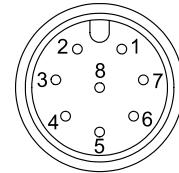

* When using multiple magnets the distance between two magnets must be min. 70 mm to identify the single magnets definitely. ** Description page 11

Connector M12, 5-pin

Signal wiring

Signal	Plug connection
Excitation +	1
Signal 1 +	2
GND	3
Signal 2 + (optional*)	4
PMU** (optional)	5

View to the sensor connector

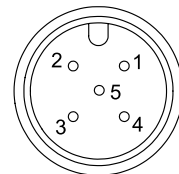

* When using multiple magnets the distance between two magnets must be min. 70 mm to identify the single magnets definitely. ** Description page 11

Connector M8, 4-pin

Signal wiring

Signal	Plug connection
Excitation +	1
Excitation GND	2
Signal +	3
PMU** (optional)	4

View to the sensor connector

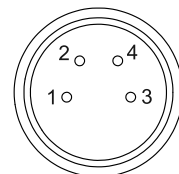

* When using multiple magnets the distance between two magnets must be min. 70 mm to identify the single magnets definitely. ** Description page 11

Option - PMU for analog output U1, U2, U8 and I1

Programming of the start and end value by the customer:

The option PMU allows to program the start value and the end value of the output range by a programming signal SPAN/ZERO available at the connector. This Signal SPAN/ZERO must be connected with GND via a push button, then position magnet of the sensor must be moved to the start resp. end position. Pushing the button between 2 and 4 seconds sets the actual position as start position, pushing the button more than 5 seconds sets the actual position as end position. The values will be stored and are available after switching off the sensor.

To reset the sensor to the factory values the button must be pushed for longer than two seconds when the sensor is switched on.

Diagnostic on analog outputs

Behaviour of the analog signal output in case of error

In case of error (magnet missing or outside the measuring range) the analog output signal will assume a state according to the following options:

Alarm_HIGH

The output voltage resp. the output current is at HIGH level (overrange).

Alarm_LOW

The output voltage resp. the output current is at LOW level (underrange).

Alarm_HOLD

The output voltage resp. the output current will keep the last valid state.

	Alarm_HIGH (standard)	Alarm_LOW (.../U)	Alarm_HOLD (.../H)
U1	$U_{out} \geq 10,5 \text{ V}$	—	keeps last valid state (Order code U1/H)
U2	$U_{out} \geq 10,5 \text{ V}$	$U_{out} < 0,25 \text{ V}$ (Order code U2/U)	keeps last valid state (Order code U2/H)
U8	$U_{out} \geq 10 \text{ V}$	$U_{out} < 0,25 \text{ V}$ (Order code U8/U)	keeps last valid state (Order code U8/H)
I1	$I_{out} \geq 21 \text{ mA}$	1,5 ... 2 mA (Order code I1/U)	keeps last valid state (Order code I1/H)

Error signal for SSI output

If the sensor cannot detect a magnet the position value will assume the maximum value (0xFFFFF).

Synchronous serial interface SSI

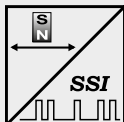

Output	RS422
Excitation voltage	10 ... 36 V DC, residual ripple 10 mV _{SS}
Excitation current	Typ. 80 mA, 150 mA max.
Clock frequency	100 kHz ... 1 MHz
Code	Gray code, dual code
Resolution	≥ 5 μm
Delay between pulse trains	>25 μs
Stability (temperature)	±50 x 10 ⁻⁶ / °C f.s.
Operating temperature	-40 ... +85 °C
EMC	EN 61326-1:2013

Description

The data transmission takes place by means of the two signals CLOCK and DATA. The processing unit (PLC, microcomputer) sends pulse sequences which clock the data transmission at the required transfer rate. With the first falling edge of the pulse sequence the position of the sensor is recorded and stored. The following rising edges control the bit-by-bit transfer of the data word. After a delay time the next new position information can be transmitted.

Data format
(Train of 26 pulses)

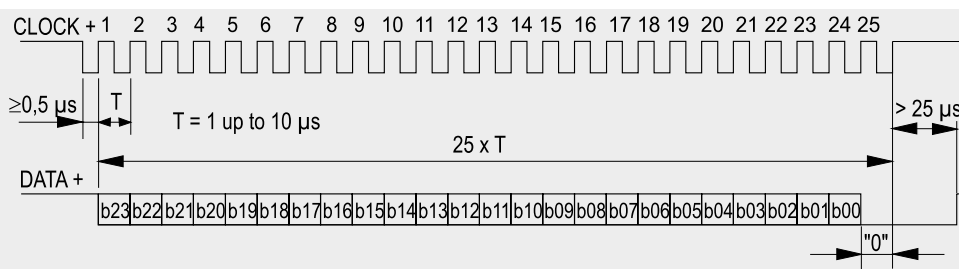

Signal diagram

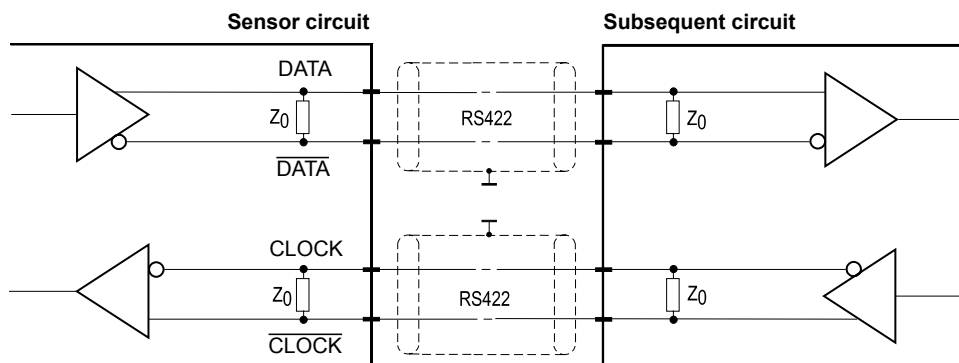

Cable length	Baud rate
50 m	100-1000 kHz
100 m	100-300 kHz

Note:
Extension of the cable length will reduce the maximum transmission rate.
The signals CLOCK/CLOCK and DATA/DATA must be connected in a twisted pair cable, common shielded.

Signal wiring

Signal	Plug connection	Cable connection (not for PCST27, PCR32)
Excitation +	1	white
Excitation GND	2	brown
CLOCK	3	green
CLOCK	4	yellow
DATA	5	grey
DATA	6	pink

View to sensor connector

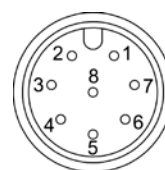

Error indication see page 11.

Description CANopen interface with process data for position and cam functions, programmable are preset, resolution, filtering and cam switching points.

Interface CANOP 	Communication profile	CANopen CiA 301 V 4.02, Slave
	Encoder profile	Encoder CiA 406 V 3.2
	Error Control	Node Guarding, Heartbeat, Emergency Message
	Node ID	Adjustable via LSS or via object dictionary
	PDO	4 TxPDO, 0 RxPDO, no linking, static mapping
	PDO Modes	Event-/Time triggered, Remote-request, Sync cyclic/acyclic
	SDO	1 server, 0 client
	CAM	8 cams
	Certified	Yes
	Transmission rates	50 kBaud to 1 MBaud, adjustable via LSS or via object dictionary
	Nodes	127 max.
	Bus connection	M12 connector, 5 pins
	Integrated bus terminating resistor	120 Ω (option)
Bus, galvanic isolated	No	

Specifications	Excitation voltage	18 ... 36 V DC
	Excitation current	Typ. 20 mA for 24 V, max. 80 mA
	Number of position magnets	1 ... 4
	Resolution	50 μm
	Measuring rate	1 kHz (asynchronous)
	Stability (temperature)	±50 x 10 ⁻⁶ / °C f.s.
	Repeatability	1 LSB
	Operating temperature	-40 ... +85 °C
	Protection	Reverse polarity, short circuit
	Dielectric strength	500 V (V AC, 50 Hz, 1 min.)
	EMC	EN 61326-1:2013

When using multiple magnets the distance between two magnets must be min. 70 mm to identify the single magnets definitely.

Signal wiring	Signal	Plug connection
	Shield	1
	Excitation +	2
	GND	3
	CAN-H	4
	CAN-L	5

View to sensor connector

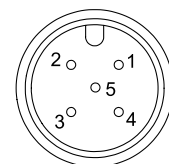

Interface J1939 	CAN specification	ISO 11898, Basic and Full CAN 2.0 B
	Transceiver	24V-compliant, not isolated
	Communication profile	SAE J1939
	Baud rate	250 kbit/s
	Internal termination resistor	120 Ω (option)
	Address	Default 247d, configurable

NAME Fields	Arbitrary address capable	0	No
	Industry group	0	Global
	Vehicle system	7Fh (127d)	Non specific
	Vehicle system instance	0	
	Function	FFh (255d)	Non specific
	Function instance	0	
	ECU instance	0	
	Manufacturer	145h (325d)	Manufacturer ID
	Identity number	0nnn	Serial number 21 bit

Parameter Group Numbers (PGN)	Configuration data	PGN EF00h	Proprietary-A (PDU1 peer-to-peer)
	Process data	PGN FFnnh	Proprietary-B (PDU2 broadcast); nn Group Extension (PS) configurable

Specifications	Excitation voltage	18 ... 36 V DC
	Excitation current	Typ. 20 mA for 24 V, max. 80 mA
	Measuring rate	1 kHz (asynchronous)
	Stability (temperature)	±50 x 10 ⁻⁶ / °C f.s.
	Repeatability	1 LSB
	Operating temperature	-40 ... +85 °C
	Protection	Reverse polarity, short circuit
	Dielectric strength	500 V (V AC, 50 Hz, 1 min.)
	EMC	EN 61326-1:2013

When using multiple magnets the distance between two magnets must be min. 70 mm to identify the single magnets definitely.

Signal wiring	Signal	Plug connection
	Shield	1
	Excitation +	2
	GND	3
	CAN-H	4
	CAN-L	5

View to sensor connector

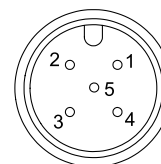

**Connector cable
M12, 5-pin
shielded**

The 5-lead shielded cable is supplied with a mating 5-pin 90° M12 connector at one end and 5 wires at the other end. Available lengths are 2 m, 5 m and 10 m. Wire: cross sectional area 0.34 mm².

Order code:

KAB - XM - M12/5F/W - LITZE
IP69K: KAB - XM - M12/5F/W/69K - LITZE

Length in m

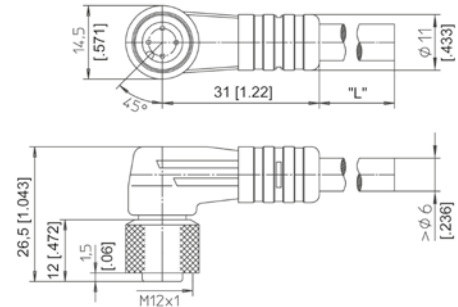

**Connector cable
M12, 5-pin
shielded**

The 5-lead shielded cable is supplied with a mating 5-pin M12 connector at one end and 5 wires at the other end. Available lengths are 2 m, 5 m and 10 m. Wire: cross sectional area 0.34 mm².

Order code:

KAB - XM - M12/5F/G - LITZE
IP69K: KAB - XM - M12/5F/G/69K - LITZE

Length in m

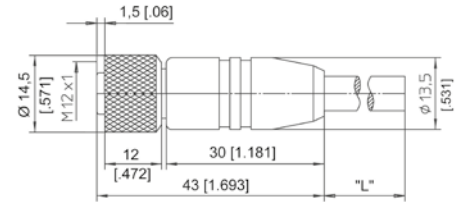

Signal wiring M12, 5-pin	Plug connection / Cable connection				
	1	2	3	4	5
	brown	white	blue	black	grey

**Connector cable
M12, 8-pin
shielded**

The 8-lead shielded cable is supplied with a mating 8-pin 90° M12 connector at one end and 8 wires at the other end. Available lengths are 2, 5 and 10 m. Wire: cross sectional area 0.25 mm².

Order code:

KAB - XM - M12/8F/W - LITZE
IP69K: KAB - XM - M12/8F/W/69K - LITZE

Length in m

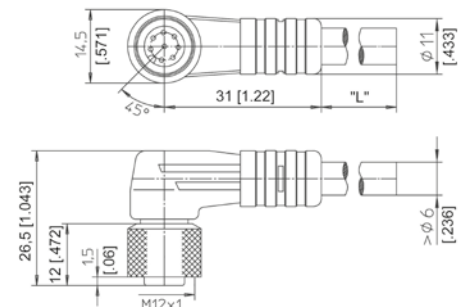

**Connector cable
M12, 8-pin
shielded**

The 8-lead shielded cable is supplied with a mating 8-pin M12 connector at one end and 8 wires at the other end. Available lengths are 2, 5 and 10 m. Wire: cross sectional area 0.25 mm².

Order code:

KAB - XM - M12/8F/G - LITZE
IP69K: KAB - XM - M12/8F/G/69K - LITZE

Length in m

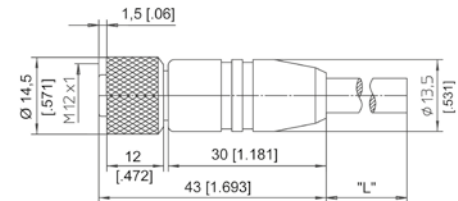

Signal wiring M12, 8-pin	Plug connection / Cable connection							
	1	2	3	4	5	6	7	8
	white	brown	green	yellow	grey	pink	blue	red

Connector/bus cable
M12, 5-pin
CAN bus
shielded

The 5-lead shielded cable is supplied with a female 5-pin M12 connector at one end and a male 5-pin M12 connector at the other end. Available lengths are 0.3 m, 2 m, 5 m and 10 m.

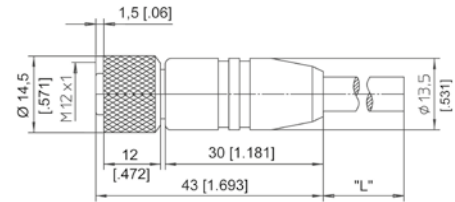

Order code:

KAB - XM - M12/5F/G - M12/5M/G - CAN

IP69K: KAB - XM - M12/5F/G/69K - M12/5M/G/69K - CAN

Length in m

T-piece for bus cable
M12, 5-pin
CAN bus

Order code:

KAB - TCONN - M12/5M - 2M12/5F - CAN

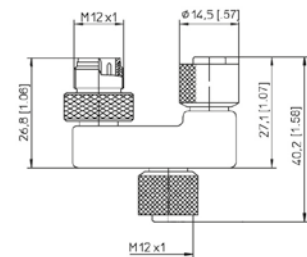

Terminating
resistance
M12, 5-pin
CAN bus

Order code:

KAB - RTERM - M12/5M/G - CAN

