

DIN BOX INDUCTIVE TRANSDUCER CONDITIONER : SX 3120 SERIES



GENERAL DESCRIPTION

The 3120 module is an inductive transducer conditioner (LVDT, RVDT and half bridge). This module has a very simple and practical adjusting of zero and scale with dip-switch and potentiometers.

Connections for power supply, transducer and output signal are made by screw terminals or plug to facilitate maintenance and installation easier.

This industrial unit in polyamide PA PHOENIX type EM, may be plugged into any common DIN EN track (EN 50022 standard).

GENERAL SPECIFICATIONS (AT 25 °C)

Power supply	24 VDC
Transducer excitation:	
- frequency	3.5 or 5 kHz
- sine voltage	1.1 or 2.2 Vrms
Output signal	0-10 V or ± 10 V and 4-20 mA
Phase shift	-20 to 15°
Synchronous	master/slave

SYNOPTIC

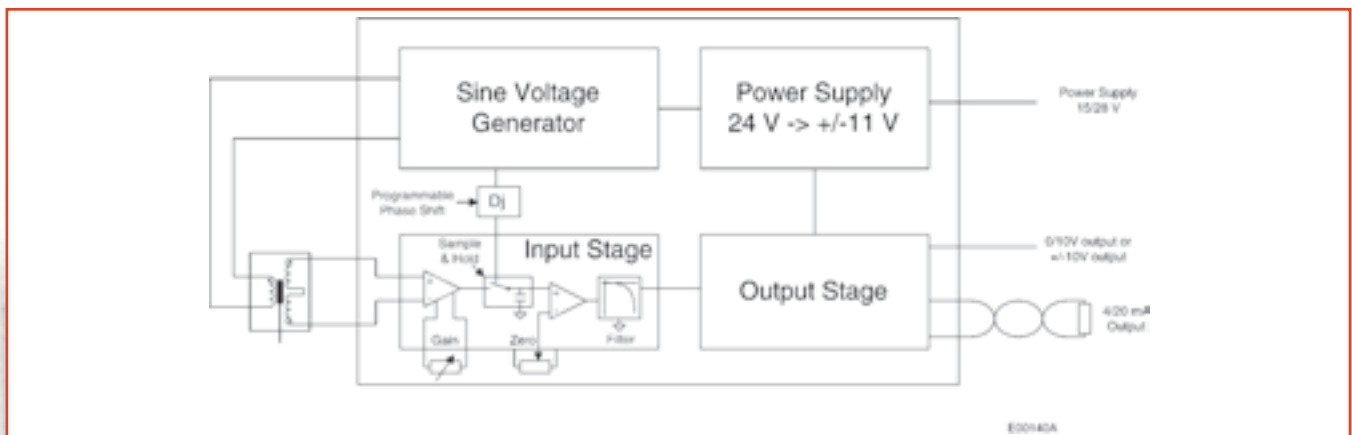

INTERFACE DRAWING

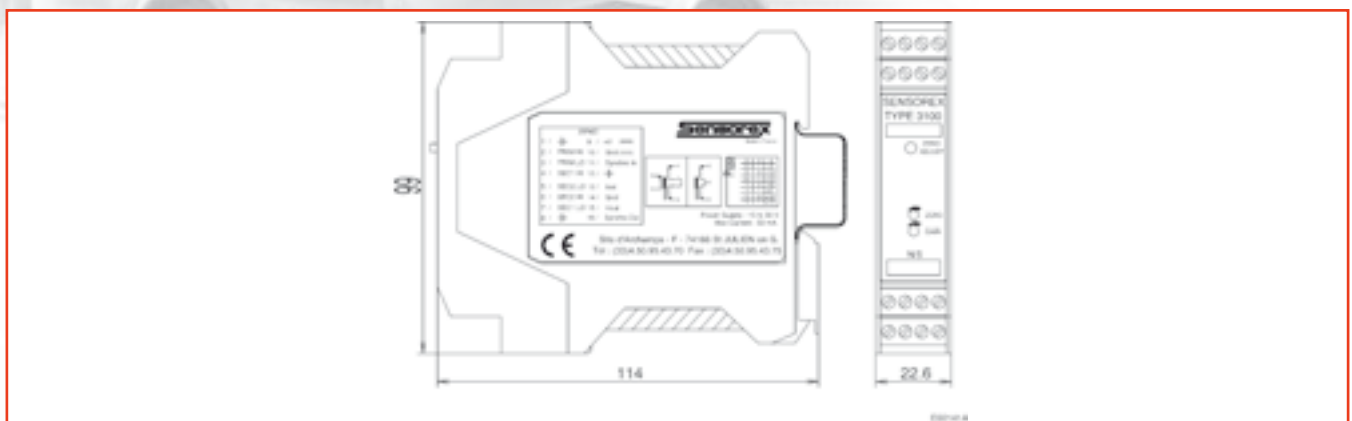

MECHANICAL CHARACTERISTICS

Fixture	track DIN EN 50022
Dimensions	115 x 100 x 23 mm
Box material	polyamide PA
Junction	screw terminal
Protection index	IP 20
Inflammability	V0 (UL94)
Vibration	2 g (white noise)
Weight	130 g approx.
Operating temperature	0 °C to 70 °C
Storage temperature	- 40 °C to + 85 °C
Temperature stabilization time	15 min.

ELECTRICAL CHARACTERISTICS (AT 25°C)

Power supply	
Power supply 24 VDC	15-28 VDC
Consumption	50 mA
Gain	
Maximum	33
Minimum	0.2
Bandwidth (second order filter)	400 Hz
Voltage output	
Output	0-10 VDC or ± 10 VC
Output short-circuit current	± 22 mA max.
Non linearity max.	± 0.04 % of FS.
Noise	15 mVpp
Current output (4-20 mA)	
Load resistor	600 Ohm max
Output impedance	40 MOhm max
Oscillator	
Frequency	3.5 or 5 kHz ± 20 %
Sine voltage	1.1 Vrms ou 2.2 Vrms ± 10 %
Primary impedance	140 Ohms min at 2.2 Vrms or 60 Ohms min at 1,1 Vrms
Thermal drift	
Excitation frequency drift	100 ppm/°C typ.
Thermal sensitivity drift	100 ppm/°C
Thermal zero drift	100 ppm/°C

WIRING

