

Druck-Ringkraftsensor zum Messen von Spannkraften

K-181

Compression Ring Force Sensor for Measurement of Clamping Forces

- Messbereich 15 kN (M6) ... 1500 kN (M52)
- Messende Unterlegscheibe
- Rostbeständiger Edelstahl
- Geringer Messweg, sehr hohe Eigenfrequenz
- Ideal zur Ermittlung von Schraubenvorspannungen
- Äußerst flaches und robustes Sensordesign
- Schutzart IP65
- *Measuring range 15 kN (M6) ... 1500 kN (M52)*
- *Measuring washer*
- *Stainless steel*
- *Low measuring range, very high natural frequency*
- *Ideal for determining bolt preload*
- *Extremely flat and robust sensor design*
- *Level of protection IP65*

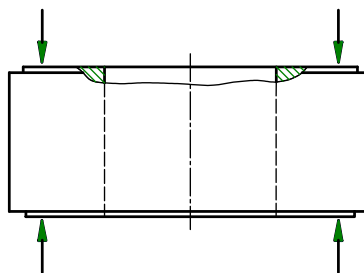
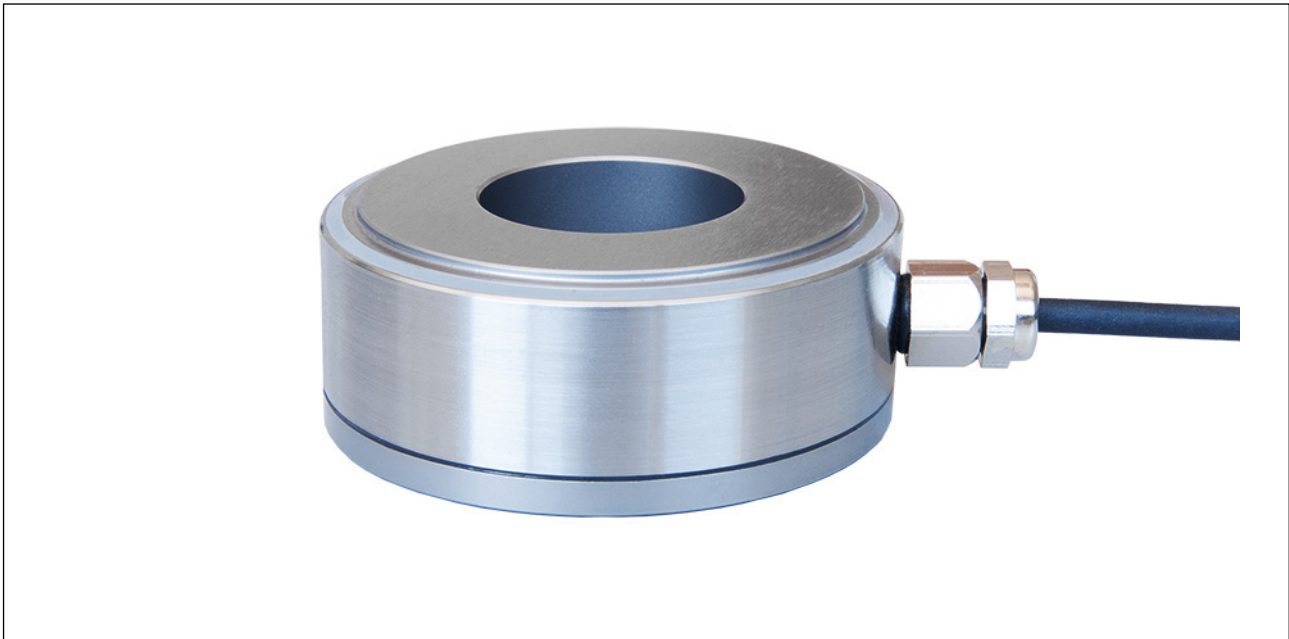

Anschlussbelegung - Connection	
Versorgung (-) - <i>Supply (-)</i>	Grün - <i>Green</i>
Versorgung (+) - <i>Supply (+)</i>	Braun - <i>Brown</i>
Signal (+) - <i>Signal (+)</i>	Gelb - <i>Yellow</i>
Signal (-) - <i>Signal (-)</i>	Weiß - <i>White</i>
Kontrollsignal (Option) - <i>Control signal (option)</i>	Grau - <i>Grey</i>
Schirm - <i>Shield</i>	Schirm - <i>Shield</i>

Mechanische Abmessungen - Dimensions¹

K-181

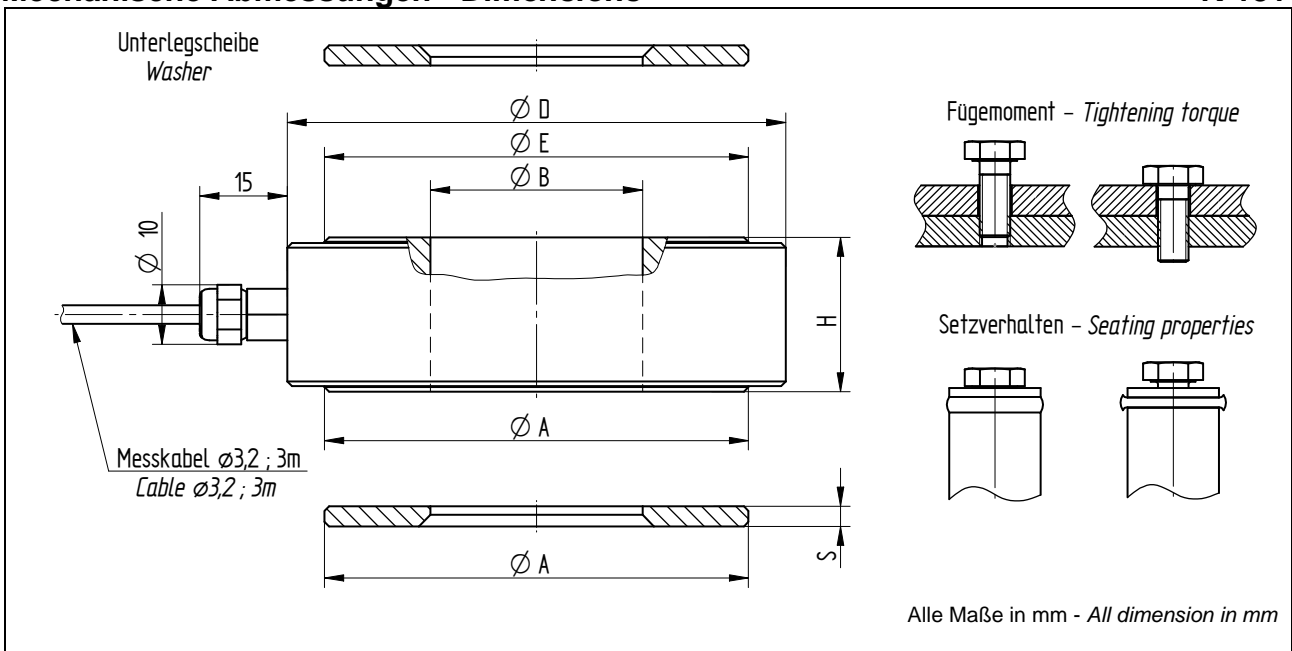

Artikel-Nr. - Article-No.	Nennkraft - Nominal force [kN]	Schraube - Screw	Ø A	Ø B	Ø D	Ø E	H	S
115715	15	M6	12	6,3	24	12	12	2
115716	30	M8	16	8,3	27	16	12	2
115717	60	M10	22	10,3	33	22	12	2
115718	80	M12	26	12,3	37	26	15	2,5
115719	120	M16	33	16,3	44	33	15	2,5
115720	160	M20	39	20,3	50	39	15	3
115770	350	M24	54	24,5	65	54	22	3
115771	500	M30	66	30,8	79	66	27	3
115772	600	M36	74	37	87	74	27	3,5
115773	720	M39	80	40	93	80	27	4
115774	1000	M42	93	43	106	93	30	4
115775	1200	M48	103	49	116	103	30	4,5
115776	1500	M52	114	53,5	127	114	35	4,5

¹ 2 Stück gehärtete Unterlegscheiben im Lieferumfang enthalten - 2 pieces hardened washers in scope of delivery.

Technische Daten - Specifications

		K-181
Genauigkeitsklasse Druckkraft - <i>Accuracy class compression force</i>	S%	1
- Unveränderte Einbaulage - <i>Unchanged installation position</i>	S%	3
- Veränderte Einbaulage - <i>Altered installation position</i>	S%	3
Gebrauchslast - <i>Service load</i>	S%	130
Grenzlast - <i>Limit load</i>	S%	150
Bruchlast - <i>Ultimate load</i>	S%	>300
Max. dynam. Belastung - <i>Max. dyn. load (DIN 50 100)</i>	S%	70
Nennmessweg - <i>Position feedback</i>	mm	<0,1
Brückenwiderstand - <i>Bridge resistance</i>	Ω	350
Isolationswiderstand - <i>Insulation resistance</i>	Ω	>2*10 ⁹
Speisespannung - <i>Supply voltage</i>	V	2 ... 6
Max. Speisespannung - <i>Max. supply voltage</i>	V	8
Nennkennwert (S) - <i>Sensitivity (S)</i>	mV/V	1 ±20%
Temp.koeff. des Kennwertes - <i>Temp. coeff. of sensitivity</i>	S%/10K	0,3
Temp.koeff. des Nullsignals - <i>Temp. coeff. of zero signal</i>	S%/10K	0,3
Referenztemperatur - <i>Reference temperature</i>	°C	23
Nenntemperaturbereich - <i>Nominal temperature range</i>	°C	0 ... 60
Gebrauchstemperaturbereich - <i>Service temperature range</i>	°C	-10 ... 70
Lagerungstemperaturbereich - <i>Storage temperature range</i>	°C	-30 ... 95
Veränderlichkeit - <i>Repeatability</i>	S%	0,3
Rel. Kriechen - <i>Rel. creep</i>	S%/30min	<±1
Werkstoff - <i>Material</i>	Rostbeständiger Edelstahl - <i>Stainless steel</i>	
Schutzart - <i>Level of protection (DIN EN 60529)</i>	IP65	
Elektrischer Anschluss - <i>Electrical connection</i>	3 m, freien Lötenden - <i>3 m, free soldered ends</i>	

Optionen - Options

Kontrollsignal - <i>Control signal</i>	S%	100
Nennkennwertabgleich (S) - <i>Sensitivity calibration (S)</i>	mV/V	1