

**Sensor box containing one sensor and one signal conditioner with 4...20mA, 2-wire output**

## Features

- robust pressure die cast aluminium housing (IP65) with saltwater proof coating
- twist free 4-point fastening of rigid, 3.2mm thick base PCB
- integrated signal conditioner with 4...20mA, 2-wire output
- temperature drift compensation
- no separate supply voltage necessary
- all SEIKA sensors fit the housing and can be installed in different directions of operation
- output signal calibrated to customer's specifications
- sensor and signal conditioner electrically isolated from housing
- EMC certified
- highly stable sensor supply voltage
- 10V ... 30V terminal voltage
- programmable dynamic response
- loop current limitation
- high overload resistance
- either connection polarity
- low pass filter with optional choice of cut-off frequency for suppression of interference frequencies

## Description

The SB11 is a pressure die cast aluminium sensor housing (IP65) with an integrated sensor for measuring uniaxial acceleration or inclination.

In addition to the sensor, the box contains a signal conditioner with 4...20mA, 2-wire output and a separate, highly stable supply voltage feeding off the current loop. Furthermore, the signal conditioner includes an active low pass filter, whose upper cut-off frequency / settling time can be adjusted to suit the measurement task, an output stage with current limitation, a noise voltage filter and a diode bridge for unipolar coupling to the current loop. Interference signals caused by unwanted ground currents are avoided by electrically isolating sensor and signal conditioner from the housing. Unlike the SB2..., the SB11 can accommodate larger inclinometers, such as the NG-series, that have a higher measuring accuracy. A special electronic temperature compensation system can significantly reduce the temperature sensitivity of the implemented sensor.

The compact metal cable gland and small housing size in combination with the 2-wire connection enable the use of this high quality measuring system in harsh operating conditions.

## Application

The SB11 is suitable for applications requiring precise inclination or acceleration measurements under harsh circumstances and returning of a 4...20mA output signal. Areas of successful implementation include construction, mining, agricultural machinery, transportation and conveyor systems, ships, operation and automation technology as well as general mechanical engineering.

**Technical Specifications**

Terminals	3 x 1.5 mm <sup>2</sup>
Cable fixing	M12 x 1.5 cable gland, clamping range 6mm ... 7.5mm
Measuring range, Resolution, etc.	dependents on implemented SEIKA sensor
Degree of protection	IP65
Mounting orientation	any
Measuring planes (N.. sensor)	3 main housing planes
Measuring plane (NG.. sensor)	parallel to bottom of housing
Measuring directions (B.., BD.. sensor)	X,Y,Z coordinates of housing
Terminal voltage	10V ... 30V
Minimum loop current	2.5mA ... 3.5mA
Maximum loop current	22mA ... 26mA
Output signal loop current	4mA ... 20mA (12mA for sensor zero position)
Adjustable variables	zero point (12mA), amplification
Maximum load resistance	500 Ohm (for 24 Volt supply voltage)
Operating temperature	-40°C ... +85°C

Options: special measuring ranges, calibration record, silicon encapsulation, custom wiring

**Dimensions of SB1I containing NG inclinometer**

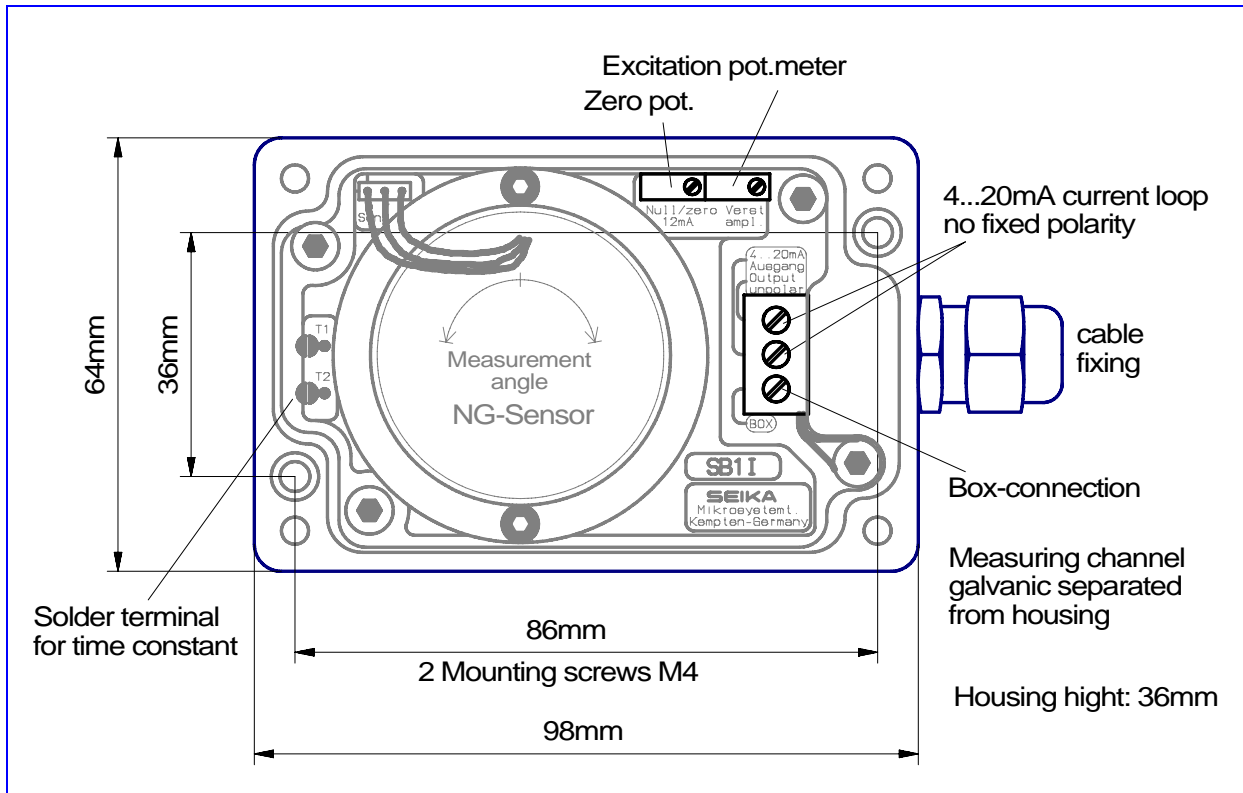

Connections

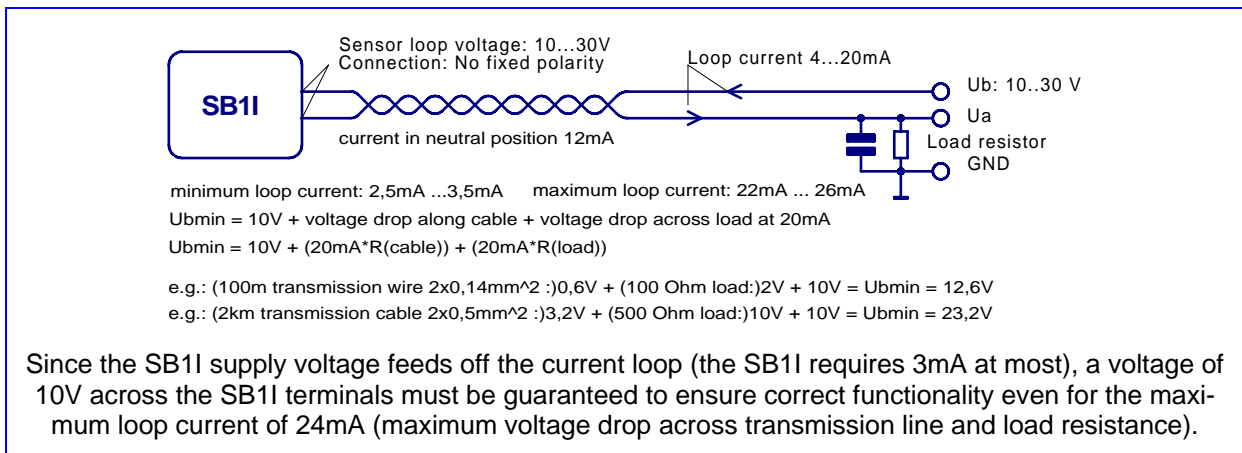

Dimensions and Measuring Directions of SB11 with N inclinometer

