

FN4055 Seat belt load cell

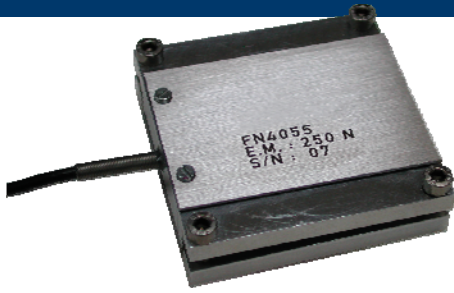

- Tension - very low range 250N
- Compatible with most seat belts
- Easy and economical maintenance
- Overload protection

DESCRIPTION

Measurement Specialties has applied our decade of experience serving the automotive crash test industry to design the ultimate crash test seat belt restraint sensor.

Created for the automobile industry, the FN 4055 measures with excellent accuracy the forces exerted on the seat belt. Only the actual compression upon the seat belt is measured, as the sensor is insensitive to contact from the crash test dummy. The unit is designed for very low range, like tests for kids security. It is protected against overload by mechanical stops.

For a new example of similar application with higher range, please read the datasheet of EL20-S458.

With many years of experience as a designer and manufacturer of sensors, Measurement Specialties, Inc. often works with customers to design or customize sensors for specific uses and testing environments.

FEATURES

- Protected against overload
- Usable without cutting the belt
- High accuracy
- 250N range, higher range with EL20 sensors

APPLICATIONS

- Automotive crash test
- Kid seats tests
- Security belts controls
- Laboratory and research

STANDARD RANGES

Ranges in N	100	250	300
Ranges in lbf	20	50	60
Over range in N w/o damage	500	1250	1500
Over range in lbf w/o damage	10	250	300

FN4055 Seat belt load cell

PERFORMANCE SPECIFICATIONS

All values are typical at temperature 20±1° C

PARAMETERS	
Operating Temperature Range (OTR)	-40 to 120° C [-4 to 176° F]
Compensated Temperature Range (CTR)	0 to 60° C [32 to 140° F]
Zero Shift in CTR	<0.02% F.S. / °C
Sensitivity Shift in CTR	<0.02 % of reading / °C
Range (F.S.)	0-100N to 0-300 N [0-20 to 0-60 lbf]
Over-Range	
Without Damage	See table
Accuracy	
Combined Non-Linearity & Hysteresis	±0.25% F.S.

Electrical Characteristics

Model	FN4055
Supply Outage	10Vdc
F.S. Output	2 mV/V
Zero Offset	±5% F.S.
Input Impedance/Consumption	350 Ω
Output Impedance	350 Ω
Insulation under 50Vdc	≥100MΩ

Notes

1. Shielded cable with 4 wires, standard length 2 m [6.5 ft]
2. Material: Body aluminium alloy
3. Protection Index: IP50

FN4055 Seat belt load cell

DIMENSIONS

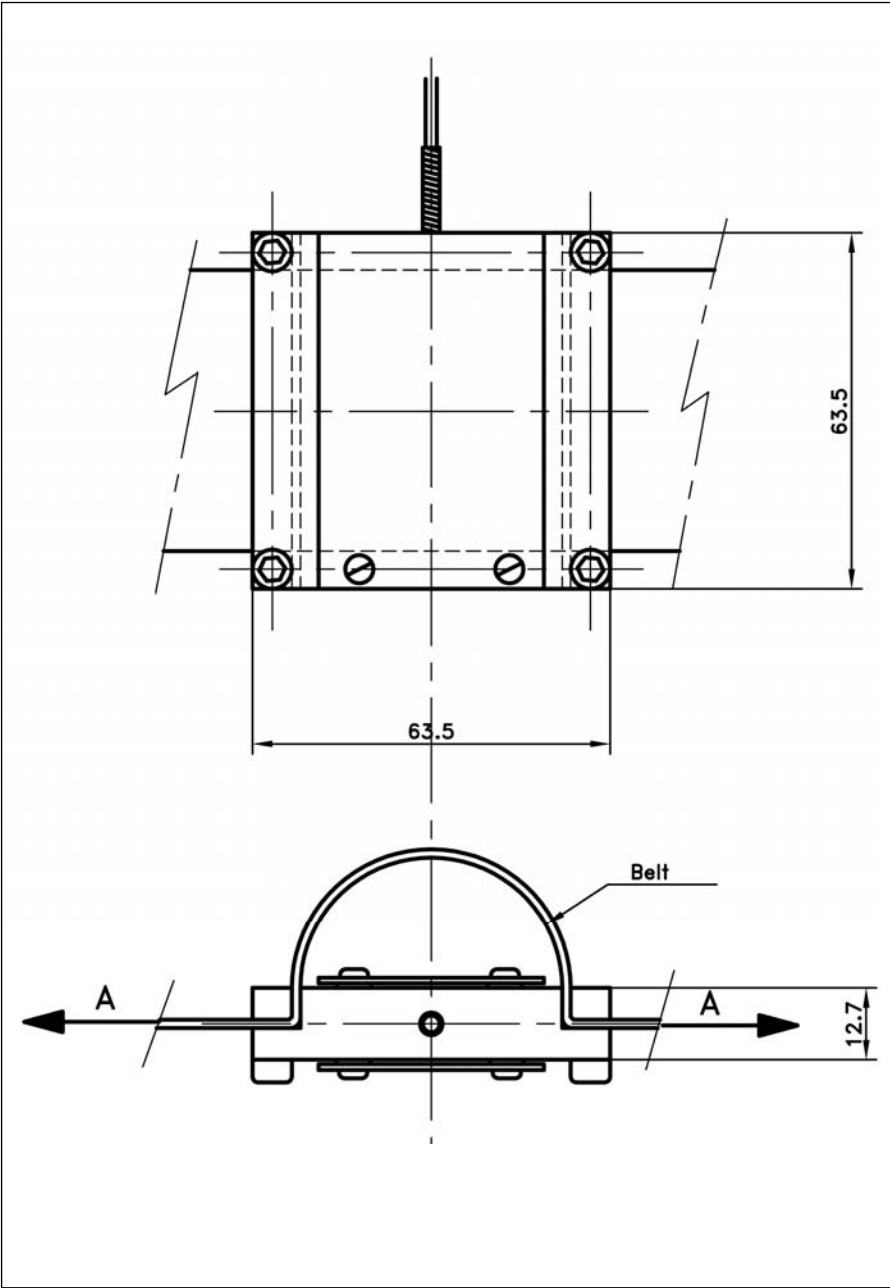

Wiring Schematic

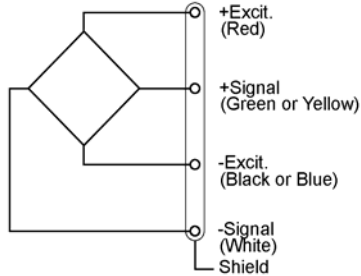

FN4055 Seat belt load cell

OPTIONS AND ACCESSORIES

L00F: Special Cable Length, replace “00” with total length in feet (Specified only on units with lbf range.)

L00M: Special Cable Length, replace “00” with total length in meter (Specified only on units with N range.)

ORDERING INFORMATION

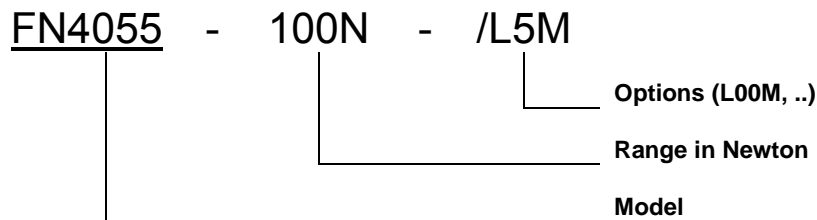

NORTH AMERICA

Measurement Specialties, Inc.
Vibration Design Center
32 Journey - Suite 150
Aliso Viejo, CA 92656
United States USA
Tel: 1-949-716-0877
Fax: 1-949-916-5677
t&m@meas-spec.com

EUROPE

Measurement Specialties
(Europe), Ltd.
26 Rue des Dames
78340 Les Clayes-Sous-Bois,
France
Tel: +33 (0) 130 79 33 00
Fax: +33 (0) 134 81 03 59
cs.lcsb@meas-spec.com

ASIA

Measurement Specialties
(China), Ltd.
No. 26 Langshan Road
Shenzhen High-Tech Park (North)
Nanshan District, Shenzhen
518057
China
Tel: +86 755 3330 5088
Fax: +86 755 3330 5099
pfg.cs.asia@meas-spec.com

The information in this sheet has been carefully reviewed and is believed to be accurate; however, no responsibility is assumed for inaccuracies. Furthermore, this information does not convey to the purchaser of such devices any license under the patent rights to the manufacturer. Measurement Specialties, Inc. reserves the right to make changes without further notice to any product herein. Measurement Specialties, Inc. makes no warranty, representation or guarantee regarding the suitability of its product for any particular purpose, nor does Measurement Specialties, Inc. assume any liability arising out of the application or use of any product or circuit and specifically disclaims any and all liability, including without limitation consequential or incidental damages. Typical parameters can and do vary in different applications. All operating parameters must be validated for each customer application by customer's technical experts. Measurement Specialties, Inc. does not convey any license under its patent rights nor the rights of others.