

The shakers used in modal testing and in-flight tests of aircrafts are usually electrodynamic shakers. However, the traditional shakers are not very portable, and the attachment process takes time. Dynalabs inertial shakers are easily mounted and has great mobility. It can be used as hand held.

The main highlights of Dynalabs inertial shaker are:

- Compact and lightweight design
- Superior low frequency performance
- Any angle mounting
- Low friction bearing guided



## Technical Specifications

Output force	5 N	10 N	20 N	40 N
Maximum peak current	1 A	4 A	4 A	4 A
Frequency range	10-1,000 Hz	10-3,000 Hz	10-3,000 Hz	10-3,000 Hz
Moving assembly mass	0.05kg	0.1 kg	0.1 kg	0.6 kg
Displacement (Peak-to-peak)	1 mm	5 mm	8 mm	12 mm
Dimension H x D	24mm x 32mm	40 mm x 42 mm	46 mm x 44.4 mm	86 mm x 71 mm
Total mass	0.06 kg	0.24 kg	0.3 kg	1.2 kg
Cooling system	Air convection	Air convection	Air convection	Air convection
Suspension	Spring	Spring	Spring	Spring
<b>AMPLIFIER</b>	External	External	External	External
Input voltage	0.5 VAC	1 VAC	1 VAC	1 VAC
Max. Input Current	1A	4A	4A	4A

## Accessories (Included for 40N)

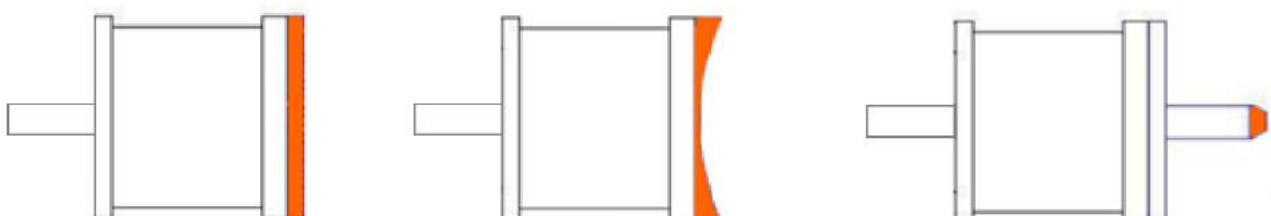

Ankara / TURKEY

info@dynamalabs.com.tr [www.dynamalabs.com.tr](http://www.dynamalabs.com.tr)

## DYNALABS INERTIAL SHAKER(DYN-IS-5)

### GENERAL CONFIGURATION

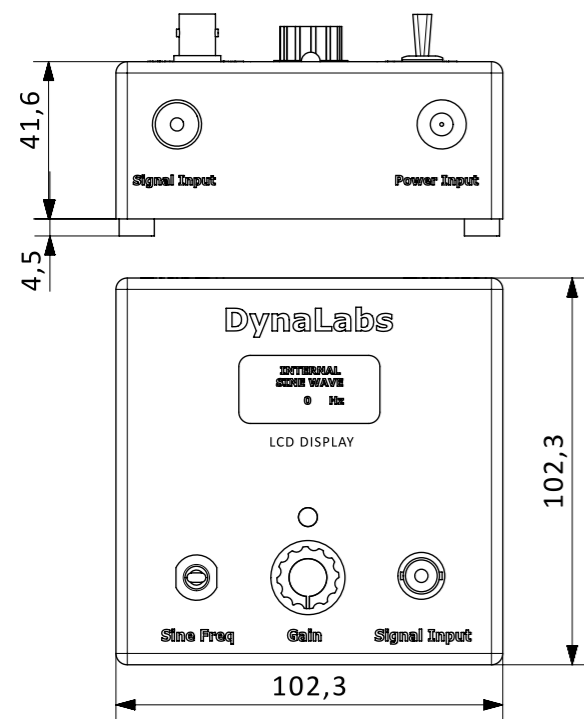
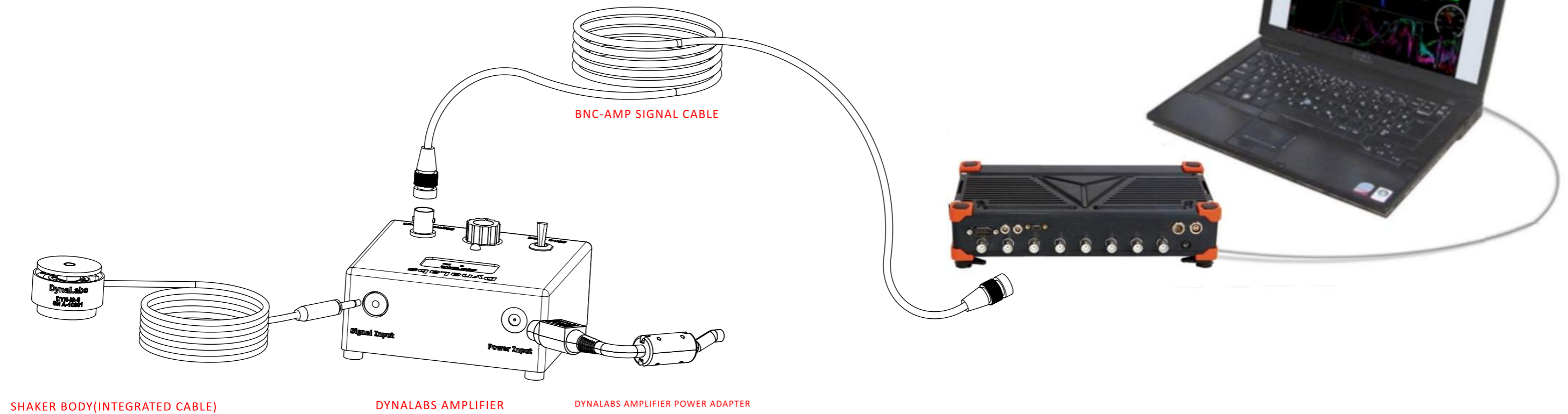

DYNALABS AMPLIFIER

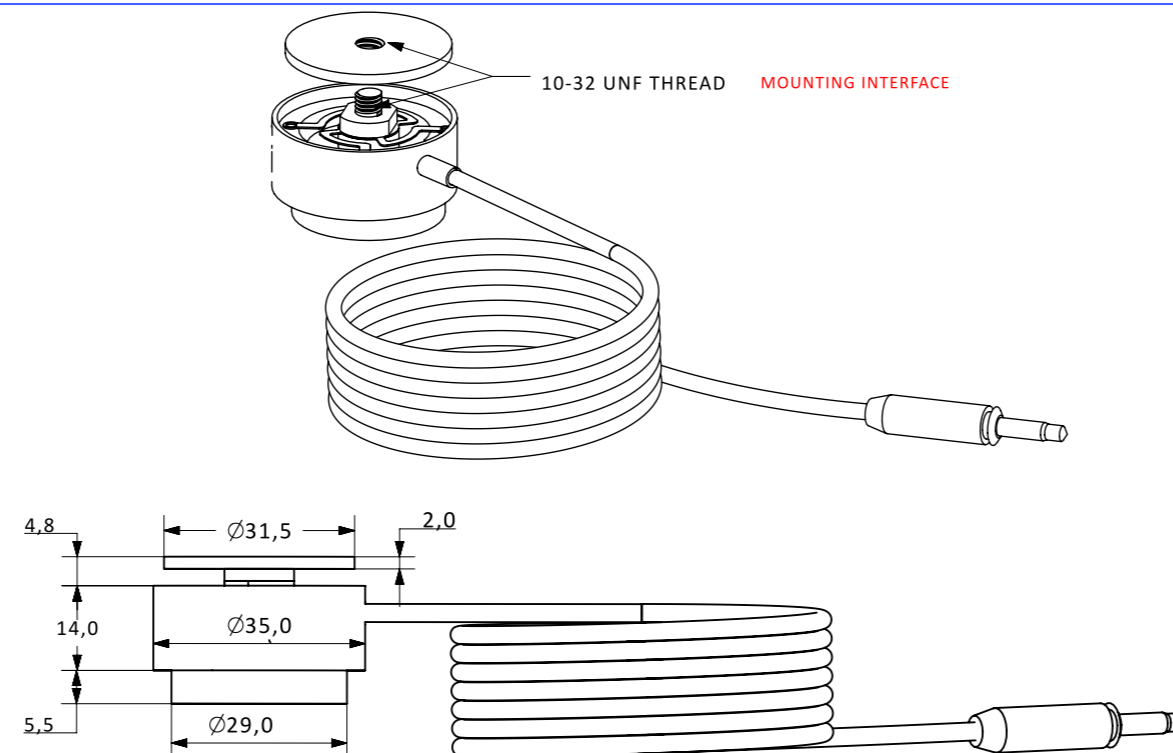

Output Force	5 N
Maksimum Peak Current	1 A
Frequency Range	10-1,000 Hz
Moving Mass	0.05 kg
Total Mass	0.06 kg
Cooling System	Air Convection
Suspension	Spring
Input Voltage	0.5 VAC
Output Current	1 A
Amplifier	External
Displacement(Peak to Peak)	1 mm

System Components : Shaker Body(Integrated Cable) + Dynalabs Amplifier + Shaker Power Cable(5 meter) + BNC-AMP Signal Cable(5 meter)+ Dynalabs Amplifier Power Adapter + User Manuel

All dimensions in mm

All rights reserved. Reproduction or issue to third parties in any form whatsoever is not permitted without written authority from the proprietors. This document is subject to change without notice, and should not be construed as a commitment or representation by Dynalabs Ltd.



## DYNALABS INERTIAL SHAKER(DYN-IS-10)

### GENERAL CONFIGURATION

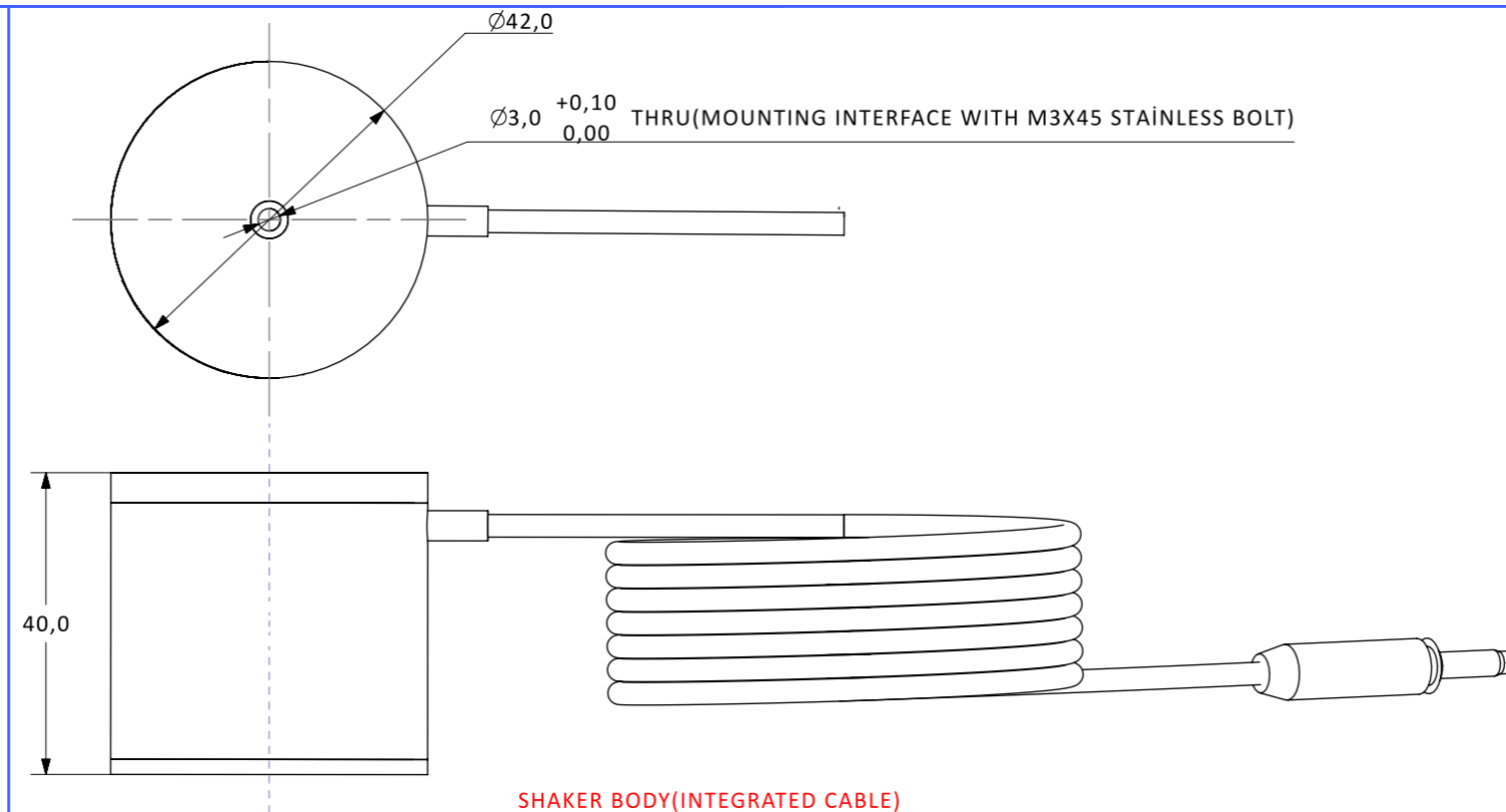
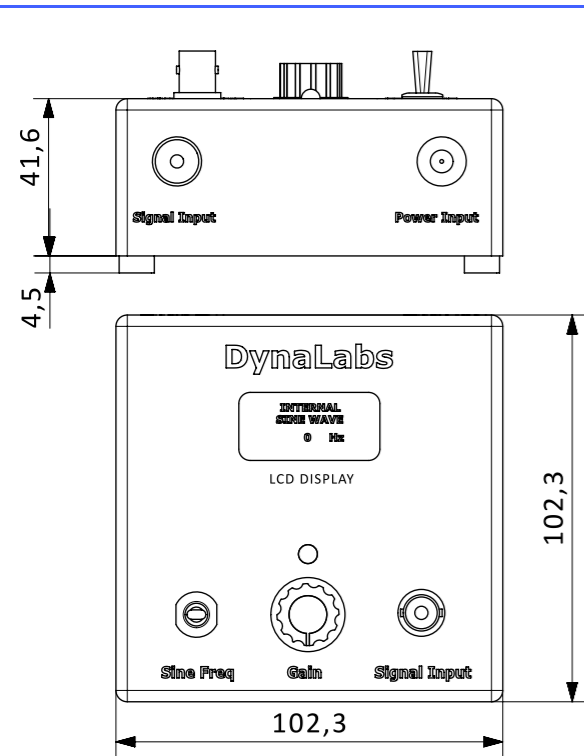
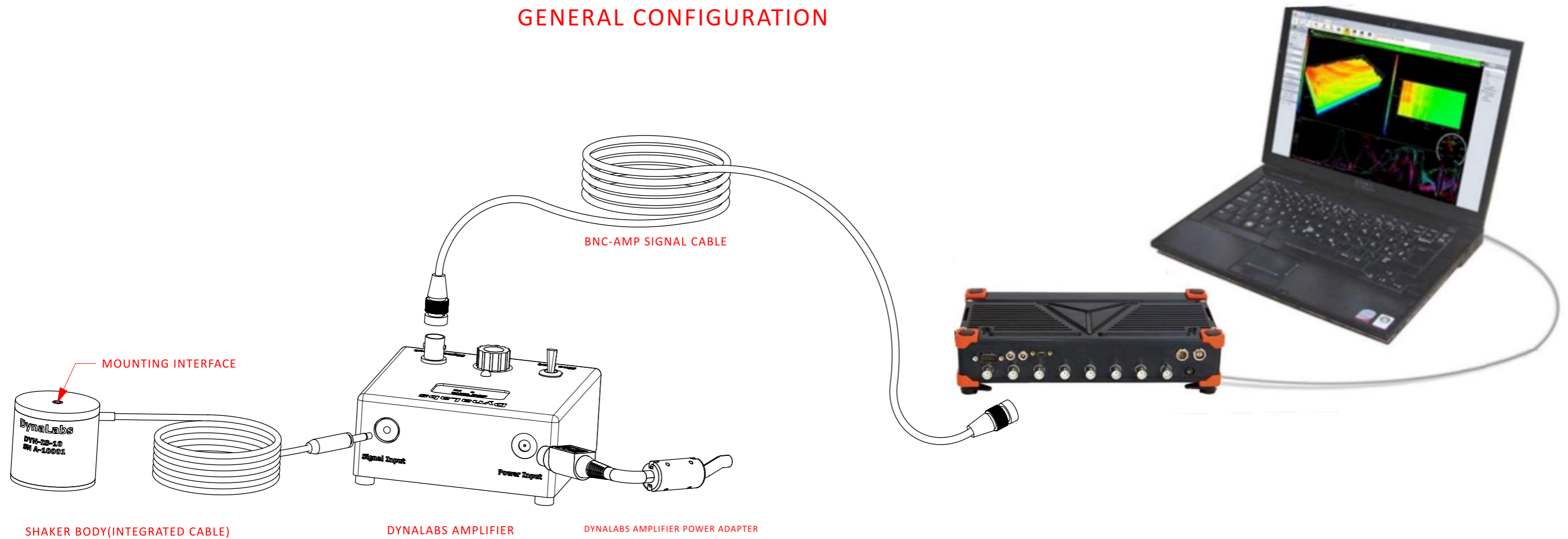

Output Force	10 N
Maksimum Peak Current	4 A
Frequency Range	10-3,000 Hz
Moving Mass	0.1 kg
Total Mass	0.24 kg
Cooling System	Air Convection
Suspension	Spring
Input Voltage	1 VAC
Output Current	4 A
Amplifier	External
Displacement(Peak to Peak)	5 mm

System Components : Shaker Body(Integrated Cable) + Dynalabs Amplifier + Shaker Power Cable(5 meter) + BNC-AMP Signal Cable(5 meter)+ Dynalabs Amplifier Power Adapter + M3X45 Stainless Bolt (2 pc)+ User Manuel

All dimensions in mm

All rights reserved. Reproduction or issue to third parties in any form whatsoever is not permitted without written authority from the proprietors. This document is subject to change without notice, and should not be construed as a commitment or representation by Dynalabs Ltd.



## DYNALABS INERTIAL SHAKER(DYN-IS-20)

### GENERAL CONFIGURATION

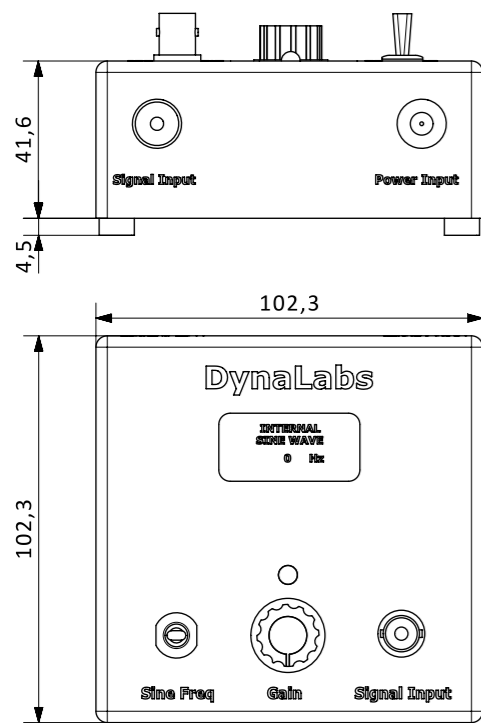
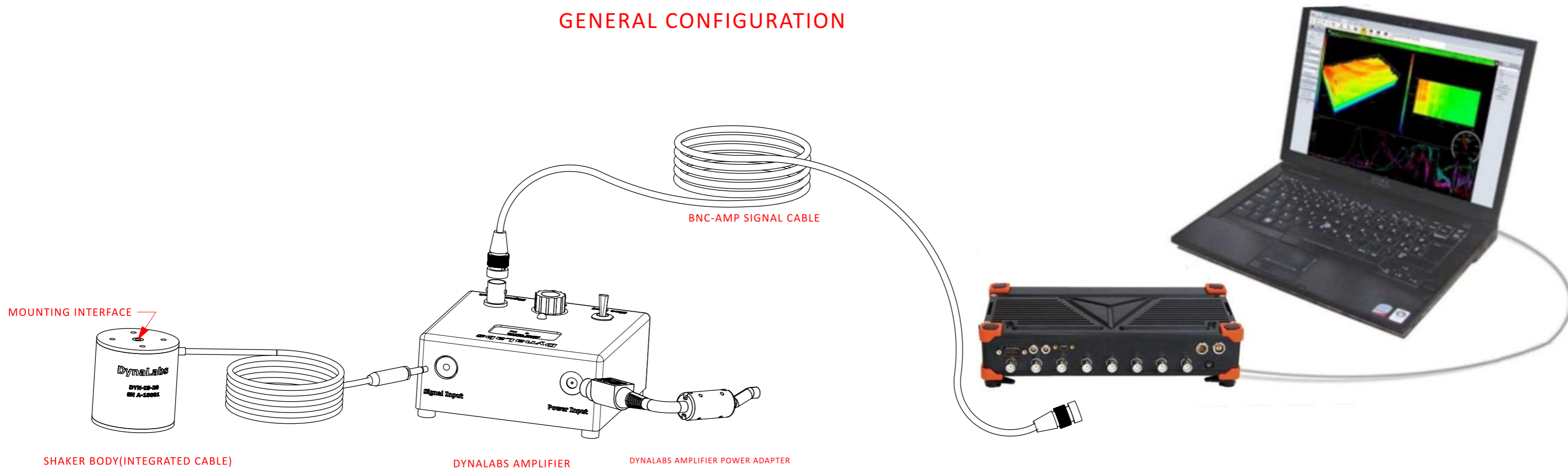

DYNALABS AMPLIFIER

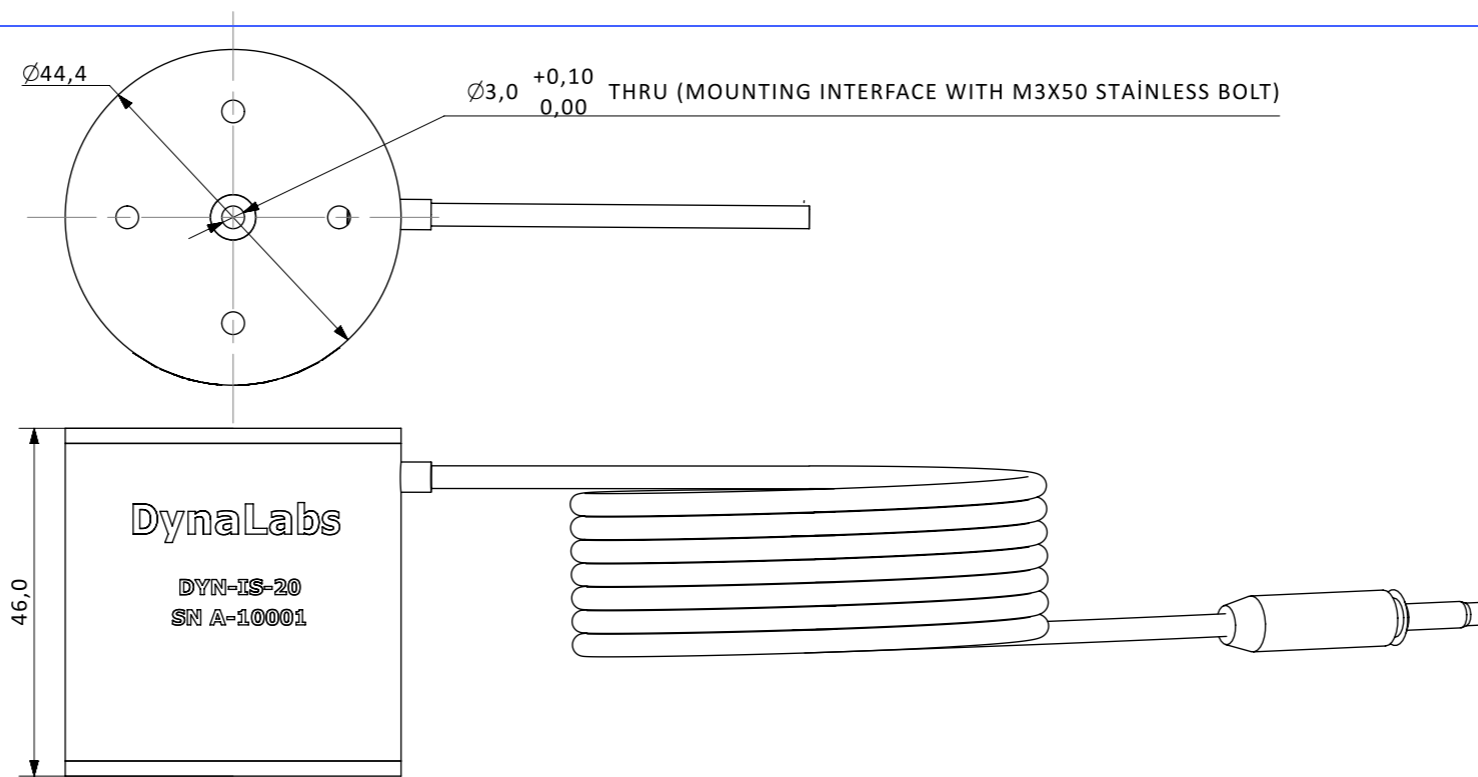

SHAKER BODY(INTEGRATED CABLE)

Output Force	20 N
Maksimum Peak Current	4 A
Frequency Range	10-3,000 Hz
Moving Mass	0.1 kg
Total Mass	0.3 kg
Cooling System	Air Convection
Suspension	Spring
Input Voltage	1 VAC
Output Current	4 A
Amplifier	External
Displacement(Peak to Peak)	8 mm

System Components : Shaker Body(Integrated Cable) + Dynalabs Amplifier + Shaker Power Cable(5 meter) + BNC-AMP Signal Cable(5 meter)+ Dynalabs Amplifier Power Adapter + M3X50 Stainless Bolt (2 pc)+ User Manuel

All dimensions in mm

All rights reserved. Reproduction or issue to third parties in any form whatsoever is not permitted without written authority from the proprietors. This document is subject to change without notice, and should not be construed as a commitment or representation by Dynalabs Ltd.



## DYNALABS INERTIAL SHAKER(DYN-IS-40)

### GENERAL CONFIGURATION

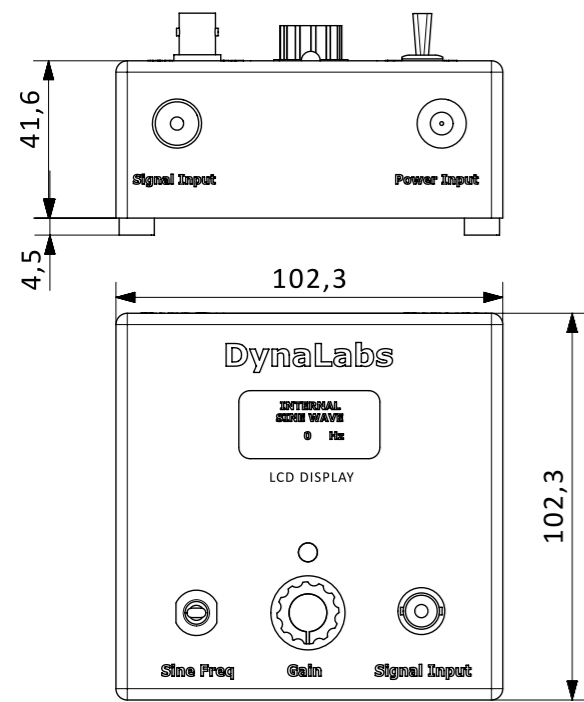
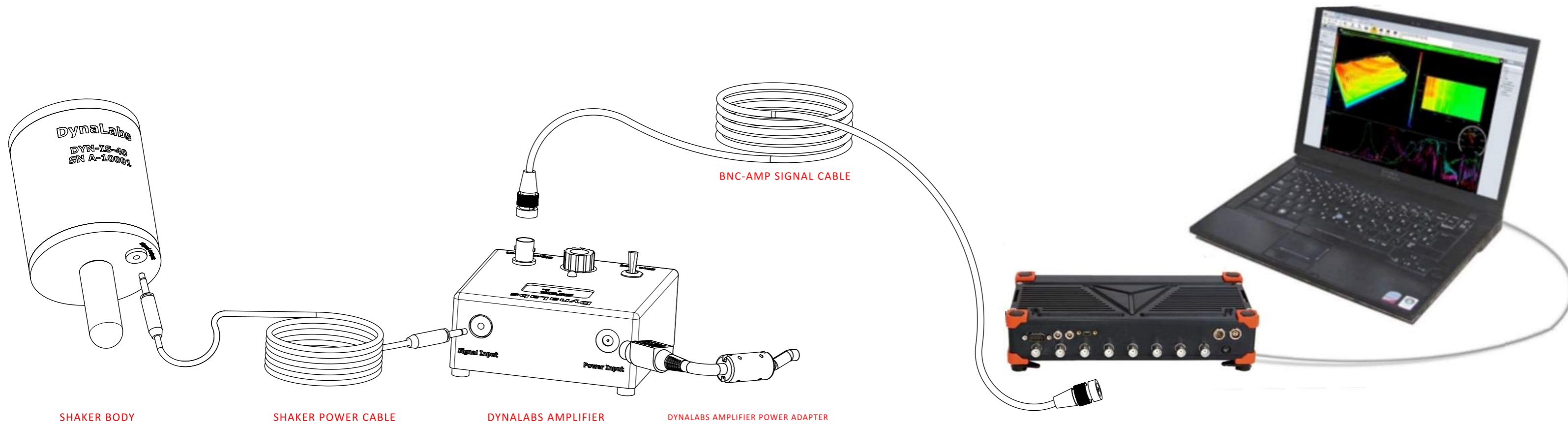

DYNALABS AMPLIFIER

### MOUNTING INTERFACE

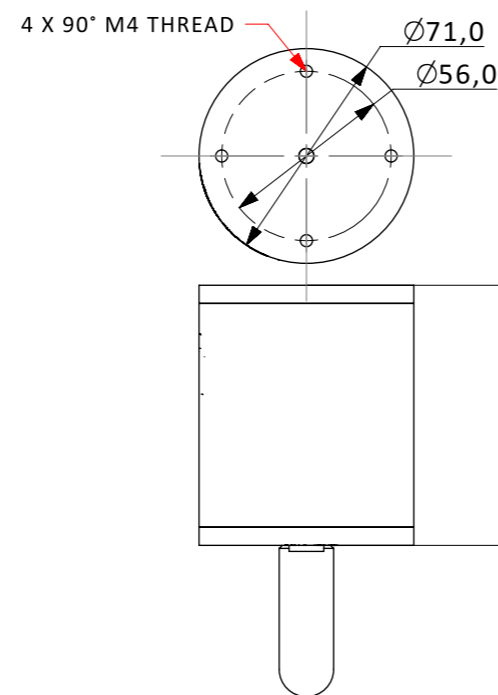

SHAKER BODY

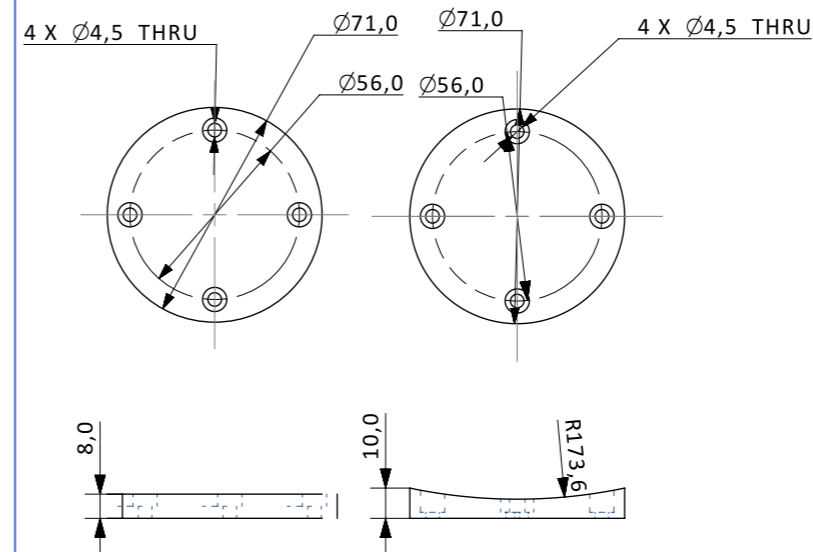

MOUNTING PLATES(MATERIAL:DELRIN)

Output Force	40 N
Maksimum Peak Current	4 A
Frequency Range	10-3,000 Hz
Moving Mass	0.6 kg
Total Mass	1.2 kg
Cooling System	Air Convection
Suspension	Spring
Input Voltage	1 VAC
Output Current	4 A
Amplifier	External
Displacement(Peak to Peak)	12 mm

System Components : Shaker Body + Dynalabs Amplifier + Shaker Power Cable(5 meter) + BNC-AMP Signal Cable(5 meter)+ Dynalabs Amplifier Power Adapter + Mounting Plates(2 pc) + M4 Stainless Bolt (5 pc)+ User Manuel

All dimensions in mm

All rights reserved. Reproduction or issue to third parties in any form whatsoever is not permitted without written authority from the proprietors. This document is subject to change without notice, and should not be construed as a commitment or representation by Dynalabs Ltd.

